



WARRANTY REGISTRATION
enviro.com/warranty

C341

DIRECT VENT FIREPLACE - IPI

OWNER'S MANUAL



WARNING: If the information in this manual is not followed exactly, a fire or explosion may result causing property damage, personal injury or loss of life. Installation and service must be performed by a qualified installer, service agency or the gas supplier.

SAFETY PRECAUTIONS



WARNING:

FIRE OR EXPLOSION HAZARD

Failure to follow safety warnings exactly could result in serious injury, death, or property damage.

- **Do not store or use gasoline or other flammable vapors and liquids in the vicinity of this or any other appliance.**

- **WHAT TO DO IF YOU SMELL GAS**
 - **Do not try to light any appliance.**
 - **Do not touch any electrical switch; do not use any phone in your building.**
 - **Leave the building immediately.**
 - **Immediately call your gas supplier from a neighbor's phone. Follow the gas supplier's instructions.**
 - **If you cannot reach your gas supplier, call the fire department.**

- **Installation and service must be performed by a qualified installer, service agency or the gas supplier.**

INSTALLER:

Leave this manual with the appliance.

CONSUMER:

Retain this manual for future reference.

This appliance may be installed in an after-market permanently located, manufactured (mobile) home, where not prohibited by local codes.

This appliance is only for use with the type of gas indicated on the rating plate. This appliance is not convertible for use with other gases, unless a certified kit is used.

Only doors certified with the appliance shall be used

Massachusetts installations (Warning): This product must be installed by a licensed plumber or gas fitter when installed within the Commonwealth of Massachusetts. Other Massachusetts code requirements: Flexible connector must not be longer than 36in., a shut off valve must be installed; only direct vent sealed combustion products are approved for bedrooms/bathrooms. A carbon monoxide detector is required in all rooms containing gas fired direct vent appliances. The fireplace damper must be removed or welded in the open position prior to installation of a fireplace insert.

SAFETY PRECAUTIONS

FOR SAFE INSTALLATION AND OPERATION OF YOUR "ENVIRO" HEATER, PLEASE CAREFULLY READ THE FOLLOWING INFORMATION:

- All ENVIRO gas-fired appliances must be installed in accordance with their instructions. Carefully read all the instructions in this manual first. Consult the building authority having jurisdiction to determine the need for a permit prior to commencing the installation.
- **NOTE:** Failure to follow these instructions could cause a malfunction of the fireplace, which could result in death, serious bodily injury, and/or property damage.
- Failure to follow these instructions may also void your fire insurance and/or warranty.

GENERAL

• Installation and repair should be done by a qualified service person. The appliance should be inspected before the first use and, at least, annually by a qualified service person. More frequent cleaning may be required due to excessive lint from carpeting, bedding material, etc. It is imperative the control compartments, burners and circulating air passageways of the appliance be kept clean.

• Due to high temperatures, the appliance should be located out of high traffic areas and away from furniture and draperies.

Children and adults should be alerted to the hazards of high surface temperatures and should stay away to avoid burn or clothing ignition.

• Young children should be carefully supervised when in the same room as the appliance. Toddlers, young children and others may be susceptible to accidental contact burns. A physical barrier is required if there is a risk for individuals in the house. To restrict access to a fireplace or stove install an adjustable safety gate to keep toddlers, young children and other at risk individuals out of the room and away from hot surfaces. Any safety screen, guard, or barrier removed for servicing an appliance must be replaced prior to operating the appliance.

• Clothing or other flammable materials should not be placed on or near the appliance.

• A barrier designed to reduce the risk of burns from the hot viewing glass is provided with this appliance and shall be installed for the protection of children and other at-risk individuals. If the barrier becomes damaged, the barrier shall be replaced with the manufacturer's barrier for this appliance.

FOR YOUR SAFETY

• Installation and service must be performed by a qualified installer, service agency or gas supplier.

• This installation must conform to local codes or, in the absence of local codes, with the National Fuel Gas Code, ANSI Z223.1/NFPA 54, or the Natural Gas and Propane Installation Code, CSA B149.1.

• To prevent injury, do not allow anyone who is unfamiliar with the stove to operate it.

• To prevent injury, if the pilot or pilot and burners have gone out on their own, open the glass door and wait 5 minutes to air out before attempting to relight the stove.

• Always keep the area around these appliances clear of combustible material, gasoline and other flammable liquids and vapours.

• These appliances should not be used as a drying rack for clothing or for hanging Christmas stockings/decorations.

• Due to the paint curing on the stove, a faint odor and slight smoking will likely be noticed when the stove is first used. Open a window until the smoking stops.

Always connect this gas stove to a vent system and vent to the outside of the building envelope. Never vent to another room or inside the building. Make sure the specified vent pipe is used, properly sized and of adequate height to provide sufficient draft. Inspect the venting system annually for blockage and signs of deterioration.

WARNING: Failure to position the parts in accordance with the diagrams in this booklet, or failure to use only parts specifically approved with this appliance, may result in property damage or personal injury.

WARNING: Do not operate with the glass front removed, cracked or broken. Replacement of the glass should be done by a licensed or qualified service person.

• Never use solid fuels such as wood, paper, cardboard, coal, or any flammable liquids, etc., in this appliance.

• Do not use this appliance if any part has been under water. Immediately call a qualified service technician to inspect the appliance and to replace any part of the control system or any gas control which has been under water.

• Do not abuse the glass by striking it or slamming the door shut.

• If the C34I unit is pulled out of its installation, and the vent-air intake system is disconnected for any reason, ensure that the vent-air intake pipes are reconnected and re-sealed in accordance to the instructions noted in INITIAL INSTALLATION - DIRECT VENT



DANGER



HOT GLASS WILL CAUSE BURNS
DO NOT TOUCH GLASS UNTIL COOLED.
NEVER ALLOW CHILDREN TO TOUCH GLASS.

A barrier designed to reduce the risk of burns from the hot viewing glass is provided with this appliance and must be installed for the protection of children and other at-risk individuals.

TABLE OF CONTENTS

Safety Precautions	2
Table of Contents	4
Codes And Approvals	6
Specifications	7
Dimensions:	7
Rating Label & Lighting Instructions Location:	7
Lighting Instructions:	8
Maintenance And Service	8
Air Shutter (Venturi):	9
Normal Sounds During Operation:	9
Routine Maintenance:	10
Cleaning The Glass:	10
Cleaning The Firebox:	10
Replacing the Glass:	10
Cleaning Decorative Surfaces:	11
Safety Screen:	11
Glass Door Removal:	12
Burner Removal:	12
Access panels:	13
Intake Shield Removal:	13
Fuel Conversion:	14
Initial Installation	16
Introduction:	16
Unit Install Preperation:	16
Steel Stud	17
Placement and Framing:	18
Clearances & Non-Combustible	19
Cool Surface Activation	20
Cool Surface System Fireplace Conversion - Ducted	21
Finishing the Fireplace.....	23
Cool Surface System Framing & Finishing - Non-Ducted.....	25
Front Opening - Non-Ducted	25
Side Opening - Non-Ducted	26
False Ceiling - Non-Ducted	26
Open Chase - Non-Ducted	27
CSS required Vent Heat Shields - Non-Ducted	27
CSS TV Installation Considerations	28
Alternate Gas Inlet Location.....	29
Vent Termination Framing:	29
Floor Protection:.....	30
Non-Combustible Platform:	30
Mantel Requirements:	30
Installation with Recess	33
Corner Installation:.....	34
Horizontal Vent install:	35
Vertical Vent install:	35

TABLE OF CONTENTS

TV Installation Considerations:	36
Direct Vent:	37
Vent Termination Restrictions:	38
Venting Clearances	39
Flex Venting.....	40
Approved Venting Parts:.....	41
Allowable Co-Axial Vent Configurations:.....	42
Exhaust Restrictor Setting:	44
Horizontal Termination:.....	45
Vertical Termination:	46
Gas Line Connection and Testing:	49
Electrical Requirements:.....	50
Secondary Installation	53
C34I Light Kit (50-3331).....	53
Burner Tray Installation:	53
Panel and Tray Media Installation:	54
Log Set Installation:	56
Flame Appearance:	57
Trouble Shooting	58
Parts Diagram.....	60
Parts List	61
Warranty	62

CODES AND APPROVALS

DIRECT VENT ONLY: This type is identified by the suffix DV. This appliance draws all of its air for combustion from outside the dwelling, through a specially designed vent pipe system.

This appliance has been tested and approved for installations from 0 feet to 4500 feet (1372 m) above sea level.

In the USA: The appliance may be installed at higher altitudes. Please refer to your American Gas Association guidelines which state: the sea level rated input of Gas Designed Appliances installed at elevations above 2000 (610 m) feet is to be reduced 4% for each 1000 feet (305 m) above sea level. Refer also to local authorities or codes which have jurisdiction in your area regarding the de-rate guidelines.

In Canada: When the appliance is installed at elevations above 4500 feet (1372 m), the certified high altitude rating shall be reduced at the rate of 4% for each additional 1000 feet (305 m).

- This appliance has been tested by INTERTEK and found to comply with the established VENTED GAS FIREPLACE HEATER standards in CANADA and the USA as follows:

VENTED GAS FIREPLACE HEATER (C34; NATURAL GAS, PROPANE GAS)

TESTED TO: ANSI Z21.88 / CSA 2.33 VENTED GAS FIREPLACE HEATERS
CSA 2.17 GAS FIRED APPLIANCES FOR HIGH ALTITUDES

This ENVIRO C34I Fireplace:

- Has been certified for use with either natural gas or propane (see rating label).
- Is not for use with solid fuels.
- Is approved for a bedroom or bed sitting room. (**IN CANADA:** Using the supplied remote control or other thermostat control. **IN USA:** see current ANSI Z223.1 for installation instructions.)
- Must be installed in accordance with local codes. If none exist, use current installation code CAN/CGA B149.1 in Canada or ANSI Z223.1/NFPA 54 in the USA.
- Must be properly connected to an approved venting system and not connected to a chimney flue serving a separate solid-fuel burning appliance.

IMPORTANT NOTICE (Regarding first fire up): When the unit is turned on for the first time, it should be turned onto high without the fan on (if equipped) for the first 4 hours. This will cure the paint, logs, gasket material and other products used in the manufacturing process. It is advisable to open a window or door, as the unit will start to smoke and can irritate some people. After the unit has gone through the first burn, turn the unit off including the pilot, let the unit get cold then remove the glass door and clean it with a good gas fireplace glass cleaner, available at your local ENVIRO dealer.

**NATIONAL
FIREPLACE
INSTITUTE**



CERTIFIED

www.nficertified.org

We recommend that our gas hearth products be installed and serviced by professionals who are certified in the U.S. by the National Fireplace Institute® (NFI) as NFI Gas Specialists.

SPECIFICATIONS

DIMENSIONS:

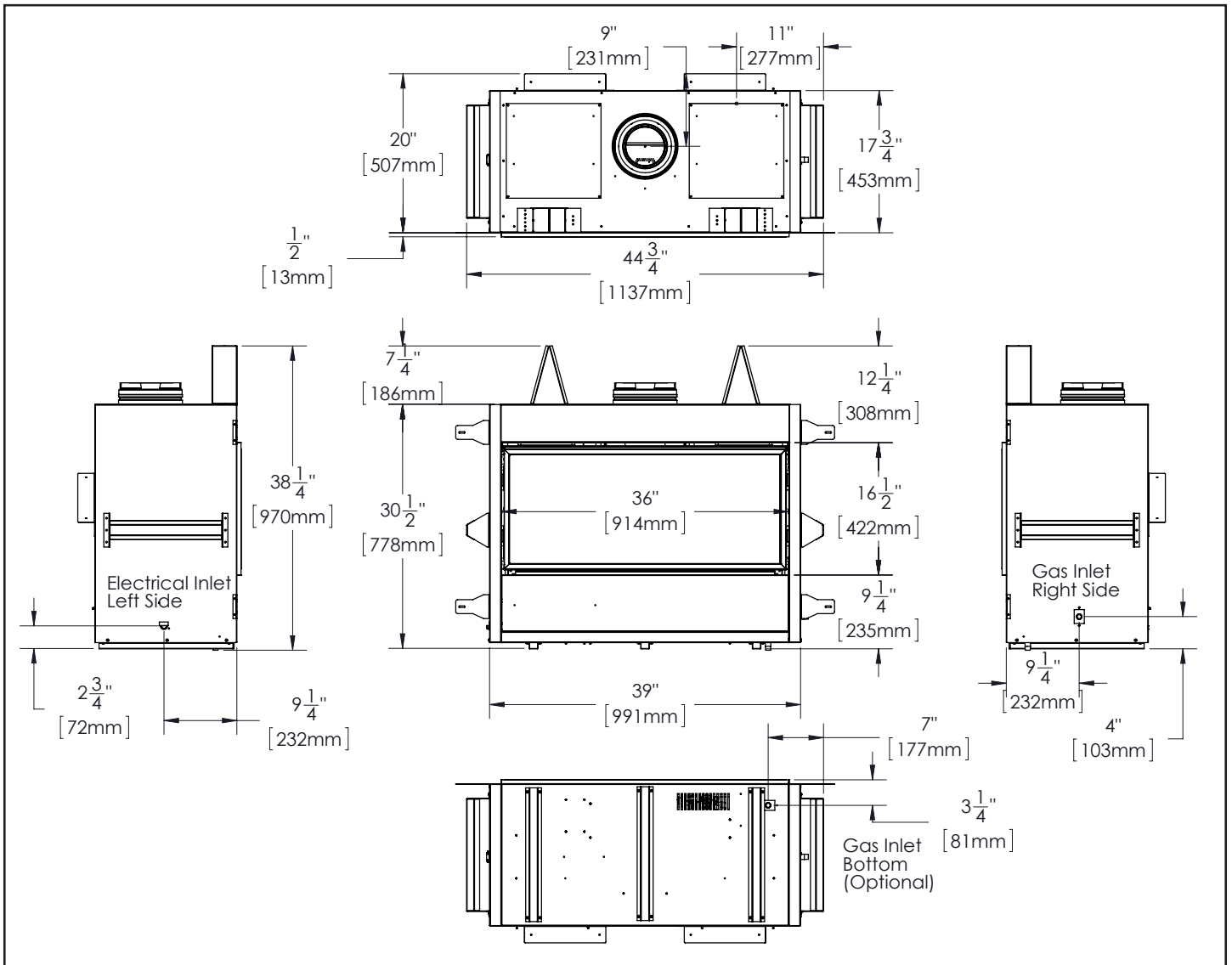

Figure 1: Unit Dimensions

RATING LABEL & LIGHTING INSTRUCTIONS LOCATION:

Rotate the safety screen upward or remove the screen completely to access the rating label and lighting instructions. The plates are attached to a length of chain and are never to be tampered with or removed. All important information for your fireplace is on this label as well of the model specific serial number which you will need for warranty information. The plates are located inside the cabinet on the left side at the front.

LIGHTING INSTRUCTIONS

For Your Safety, Read Safety Precautions And Lighting Instructions Before Operating

WARNING: IF YOU DO NOT FOLLOW THESE INSTRUCTIONS EXACTLY A FIRE OR EXPLOSION MAY RESULT, CAUSING PROPERTY DAMAGE, PERSONAL INJURY OF LOSS OF LIFE.

LIGHTING INSTRUCTIONS:

FOR YOUR SAFETY READ BEFORE OPERATING

WARNING: IF YOU DO NOT FOLLOW THESE INSTRUCTIONS EXACTLY, A FIRE OR EXPLOSION MAY RESULT CAUSING PROPERTY DAMAGE, PERSONAL INJURY OR LOSS OF LIFE.

- A. This appliance is equipped with an ignition device which automatically lights the pilot. Do not try to light the pilot by hand.
- B. BEFORE OPERATING smell all around the appliance area for gas. Be sure to smell next to the floor because some gas is heavier than air and will settle on the floor.
- WHAT TO DO IF YOU SMELL GAS:
- Do not try to light any appliance.
 - Do not touch any electrical switch; do not use any phone in your building.
 - Immediately call your gas supplier from a neighbor's phone. Follow the gas supplier's instructions.
 - If you cannot reach your gas supplier, call the fire department.
- C. Use only your hand to push in or turn the gas control knob. Never use tools. If the knob will not push in or turn by hand, don't try to repair it, call a qualified service technician. Force or attempted repair may result in a fire or explosion.
- D. Do not use this appliance if any part has been under water. Immediately call a qualified service technician to inspect the appliance and to replace any part of the control system and any gas control which has been under water.

OPERATING INSTRUCTIONS

1. STOP! Read the safety information above on this label.
2. Read the owner's manual including the section on "Remote Control" operation.
3. Set the thermostat to the lowest setting.
4. Turn off all electric power to the appliance.
5. Do not attempt to light the pilot by hand.
6. Wait five (5) minutes to clear out any gas. Then smell for gas, including near the floor. If you smell gas, STOP! Follow "B" in the safety information above on this label. If you don't smell gas, go to the next step.
7. Turn on all electric power to the appliance.
8. Using the remote control, set thermostat to desired setting, or press the ON/OFF key on the remote. "ON" will be indicated on the display of the remote and an audible "beep" will be heard at the unit to indicate the command has been received.
9. This appliance is equipped with a completely automatic ignition and lighting control. The control will attempt to light the pilot several times if necessary. If it is unsuccessful, it will discontinue operations. If the appliance will not operate, follow the instructions "To Turn Off Gas To Appliance" and call your service technician or gas supplier.

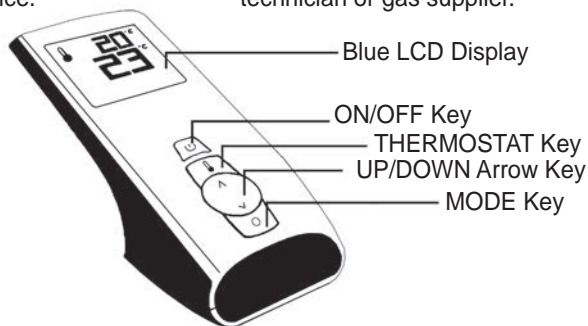

TO TURN OFF GAS TO APPLIANCE

1. Set thermostat to lowest setting, or press the ON/OFF Key. "OFF" will be indicated on the display and an audible "Beep" will be heard at the unit to indicate the command has been received.
2. Turn off all electric power to the appliance if service is to be performed.

C-12455

Figure 2: IPI Lighting Instruction Label

MAINTENANCE AND SERVICE

AIR SHUTTER (VENTURI):

The air shutter plays a very important role in flame appearance and combustion quality. The shutter adjusts how much air gets mixed with the gas before it ignites. Adjustments can be made to accommodate various climates and vent configurations.

To gain access to the air shutter remove the safety screen and intake shield. There is a lever underneath the firebox near the gas valve as shown in Figure 3. Moving the lever to the right will close off the air mixing with the gas and will make the flame appear more yellow and tall. Moving the lever to the left will open up the shutter allowing more air to be mixed with the incoming gas; this will make the flames appear more blue and short.

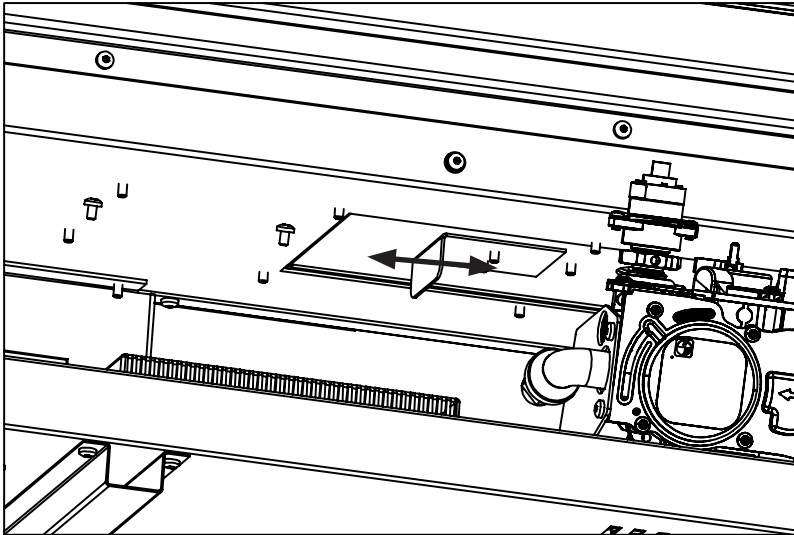

Figure 3: Air shutter adjustment lever

Typically natural gas flames will require the shutter to be more closed.

Typically LP flames will require the shutter to be more open.

If you cannot attain the proper flame by making air shutter adjustments then you may have the incorrect exhaust restrictor.

If the flame is very flickery, fast moving, and low then increase the restriction.

If the flame is very tall, lazy, and dirty then decrease the restriction.

More details can be found in the venting section of this manual.

Caution: Wear heat resistant gloves when making adjustments to the air shutter. Perform adjustments after 15 minutes.

NORMAL SOUNDS DURING OPERATION:

Table 1: Normal Sounds

Component	Sound & Reason
Main Unit	Creaking when heating up or cooling down.
Burner	Light pop or poof when turned off; this is more common with LP units.
Temperature Sensor	Clinking when it senses to turn the blower on or off.
Pilot Flame	Quiet whisper while the pilot flame is on.
Blower / Fan	Air movement that increase and decreases with the speed of the blower. The blower is pushing the heat from the fireplace into the room.
Gas Control Valve	Dull click when turning on or off, this is the valve opening and closing.

MAINTENANCE AND SERVICE

ROUTINE MAINTENANCE:

At least once a year, run through the following procedures to ensure the system is clean and working properly. Check the burner to see if all the ports are clear and clean. Check the pilot to make sure it is not blocked by anything. The pilot flame should be blue with little or no yellow on the tips.

Warning: Clearances must be sufficient to allow access for maintenance and service.

Warning: Failure to position the parts in accordance with this manual, or failure to use only parts specifically approved with this appliance may result in property damage or personal injury.

The venting system must be periodically examined; it is recommended the examination is done by a qualified agency.

CLEANING THE GLASS:

When the fireplace has cooled, remove the safety screen and glass door. See MAINTENANCE AND SERVICE - GLASS DOOR REMOVAL. Check the gasket material on the back of the glass, making sure that it is attached and intact.

During a cold start up, condensation will sometimes form on the glass. This is a normal condition with all fireplaces. However, this condensation can allow dust and lint to cling to the glass surface. Initial paint curing of the appliance can leave a slight film behind the glass, a temporary problem. The glass will need cleaning about two weeks after installation. **Use a mild glass cleaner and a soft cloth. Abrasive cleaners will damage the glass and painted surfaces.** Depending on the amount of use, the glass should require cleaning no more than two or three times a season. **Do not clean the glass when it is hot.**

CLEANING THE FIREBOX:

Remove the logs carefully, as they are very fragile. Gently remove all the media and place on a paper towel. Vacuum the bottom of the firebox thoroughly. Carefully clean any dust off the logs and remove any lint from the burner and pilot. At this time, inspect the burner tube for cracking or severe warping. If a problem is suspected, contact the dealer. Check the logs for deterioration or large amounts of soot; a small amount on the bottom side of the logs is normal. Replace the logs as shown in the SECONDARY INSTALLATION - LOG SET INSTALLATION section. If new/more media is required, contact your nearest ENVIRO dealer.

REPLACING THE GLASS:

The glass in the fireplace is a high temperature ceramic. If the glass is damaged in any way, a factory replacement is required (see PARTS LIST). Wear gloves when handling damaged glass door assembly to prevent personal injury. Do not operate with the glass front removed, cracked or broken. Removal and replacement of the glass from the door **must** be done by a licensed or qualified service person. **The glass must be purchased from an ENVIRO dealer. No substitute materials are allowed.** To remove the door (see page 11). The replacement glass will come with a new gasket installed. Remove any silicone remnants from the door. Apply high temperature silicone to the two vertical faces of the door and install the new piece of glass with gasket (be sure to maintain edge clearances). Apply even pressure to the glass to allow the silicone to adhere to the gasket material.

MAINTENANCE AND SERVICE

CLEANING DECORATIVE SURFACES:

Painted and porcelain faces should be wiped with a damp cloth periodically. If a plated face has been purchased, it should be unpacked/unwrapped carefully to avoid getting anything on the surface of the finish, including cleaners, polish and finger prints. It is important to note that fingerprints and other marks can leave a permanent stain on plated finishes. **To avoid this, give the face a quick wipe with denatured alcohol on a soft cloth BEFORE lighting the fireplace.** Never clean the face when it is hot. Do not use other cleaners as they may leave a residue, which can become permanently etched into the surface.

SAFETY SCREEN:

A safety screen is installed from the manufacture to protect its users from the dangers of the hot glass preceding it. There are four safety screen mounting brackets that hold the screen into position as shown in Figure 4. In order to remove the safety screen it is easiest to grab with both hands from the bottom and lift the screen up off the mounting brackets and outward.

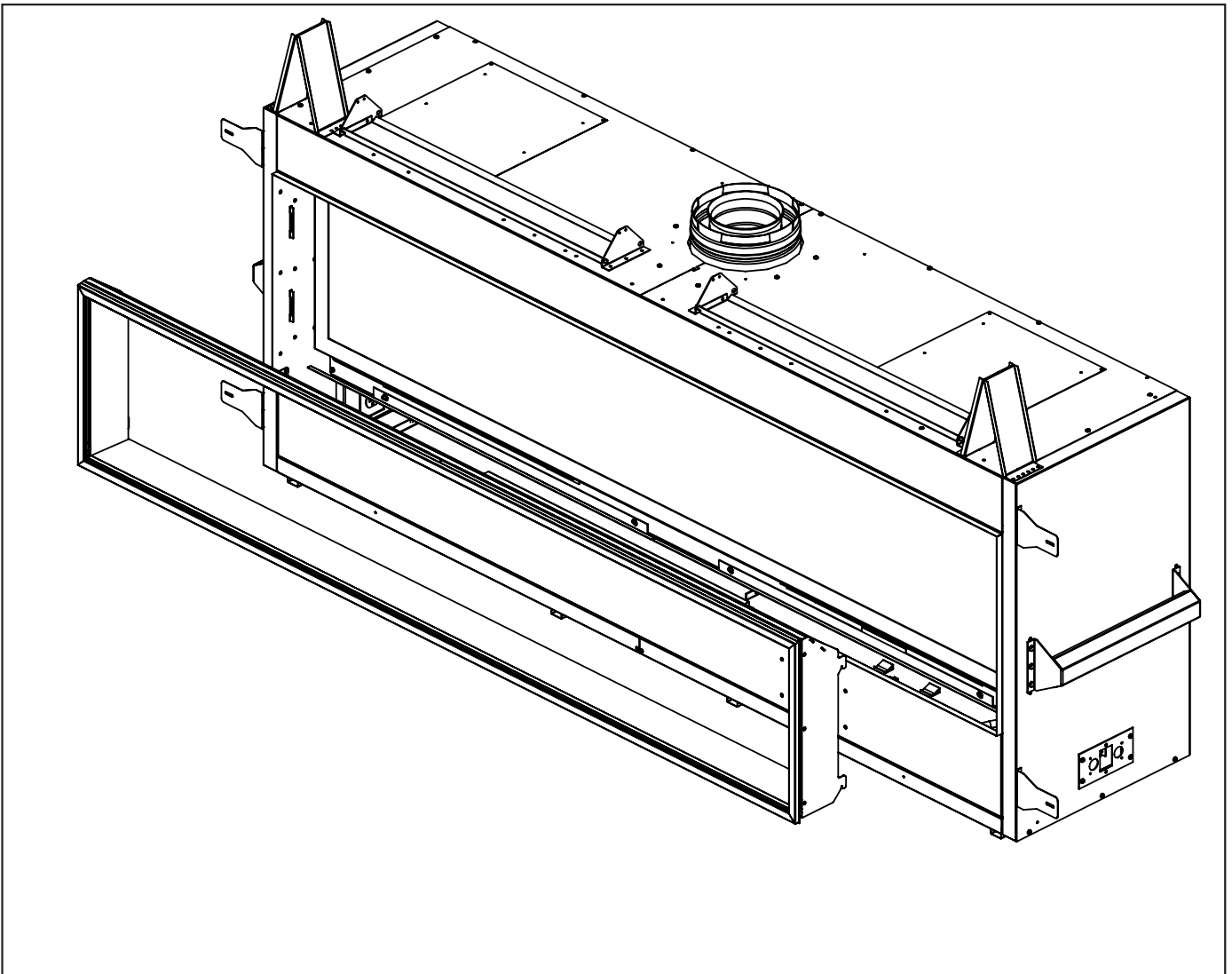

Figure 4: Safety Screen Removal

MAINTENANCE AND SERVICE

GLASS DOOR REMOVAL:

Prior to removing the glass door, first remove the safety screen as shown on the previous page. Next, the Discharge Accelerator will need to be removed from above the door as directed in the Cool Surface Activation section of this manual.

To remove the glass door use a 3/8" socket for the 3 upper bolts and then rotate the door outward. To replace the door simply reverse the order; do not over tighten the bolts or they may strip.

Note - If activating the Cool Surface System, **DO NOT** re-install the Discharge Accelerator.

WARNING: Do not touch or attempt to remove the glass door if the fireplace is not completely cold.

WARNING: Never operate the fireplace with the glass door removed.

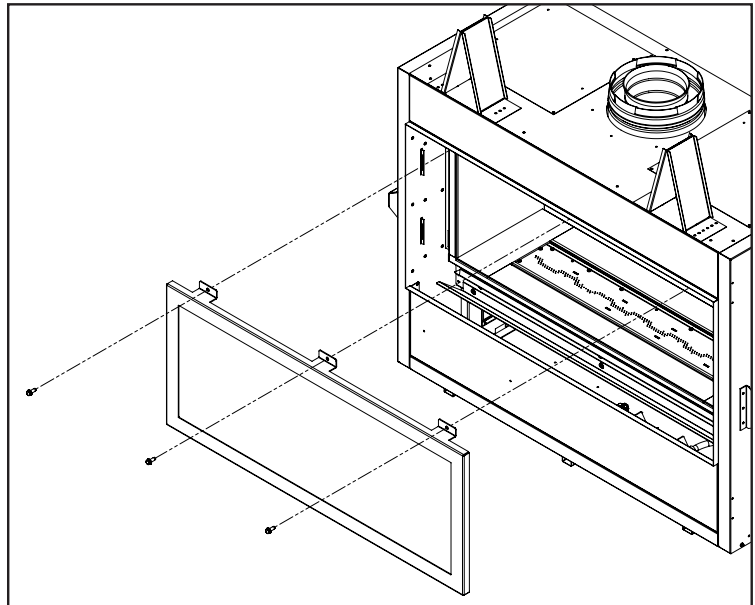

Figure 5: Door Removal Motion

BURNER REMOVAL:

The burner will need to be removed to maintenance and fuel conversion. Follow the procedure carefully. **Proceed only when the unit has completely cooled down.**

1. Remove the safety screen as shown in MAINTENANCE AND SERVICE - SAFETY SCREEN REMOVAL.
2. Remove the glass door as shown in the MAINTENANCE AND SERVICE - GLASS DOOR REMOVAL.
3. Remove log set or high definition rock set (if installed).
4. Remove any media from the media tray.
5. Remove the media tray as shown in SECONDARY INSTALLATION - MEDIA TRAY REMOVAL.
6. Remove the six T-20 screws securing the burner pan as shown in Figure 6; do NOT remove the other T-20 screws. Once the specified screws are removed slide burner to the left and lift out to remove.

To re-install the burner follow steps above in reverse. When placing the burner back in the unit be sure not to move the air shutter. **Make sure the burner is slid all the way in or the mounting holes will not line up. Do not over tighten the burner screws or they might strip; just get them snug.**

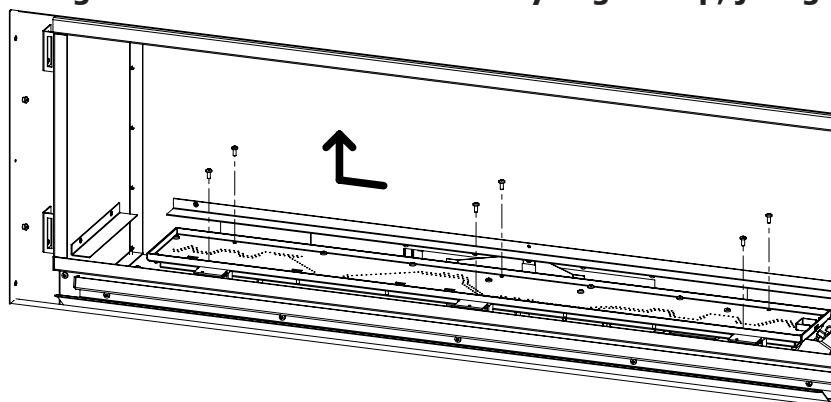

Figure 6: Removing Burner

MAINTENANCE AND SERVICE

ACCESS PANELS:

There are two access doors in the bottom on the firebox that is used for servicing components after the unit is installed in a construction enclosure. **Proceed only when the unit has completely cooled down.**

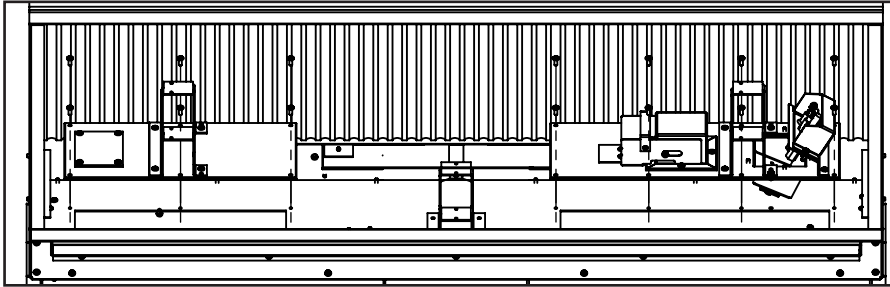

Figure 7: Removing Access Door

1. Remove the burner and burner tray as shown in the MAINTENANCE AND SERVICE - BURNER REMOVAL.
2. Remove the (14) T-20 bolts retaining the access panels as shown in Figure 7.
3. After servicing assemble in the reverse order and be sure the gasket is still intact. Replace if necessary.

INTAKE SHIELD REMOVAL:

You will need to remove the Intake Shield to gain access to the components below and make adjustments to the air shutter. To remove the shield simply lift it up off the slots.

DO NOT run the unit without the Intake Shield as it allows the unit to evacuate heat out of the unit and protect the components.

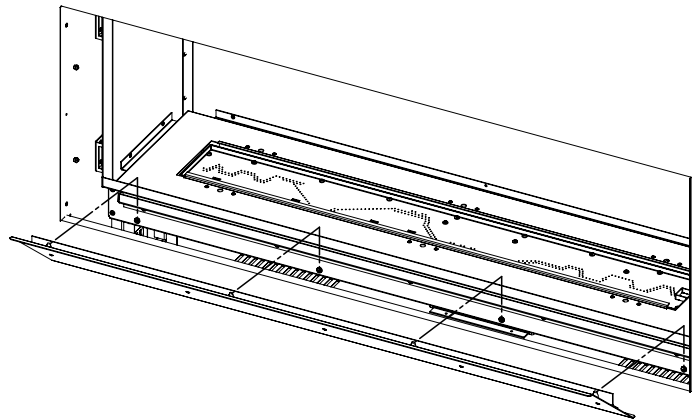

Figure 8: Removing Intake Shield

FUEL CONVERSION

TO BE INSTALLED BY A QUALIFIED SERVICE AGENCY ONLY

Please read and understand these instructions before installing.

Warning: This conversion kit shall be installed by a qualified service agency in accordance with the manufacturer's instructions and all applicable codes and requirements of the authority having jurisdiction. If the information in these instructions is not followed exactly, a fire, explosion or production of carbon monoxide may result causing property damage, personal injury or loss of life. The qualified service agency is responsible for the proper installation of this kit. The installation is not proper or complete until the operation of the converted appliance is checked as specified in the manufacturer's instructions supplied with the kit.

Kit Parts List for C34I Model:

- | | |
|--|------------------------------------|
| 1 - Orifice (NG - #37 DMS or LP - #52 DMS) | 1 - Installation instruction sheet |
| 1 - Stepper regulator with hardware | 2 - Conversion labels |
| 1 - Pilot Orifice (NG: 0.2) or (LP: 0.14) | |

Carefully inspect all parts supplied with this conversion kit. If any parts have been damaged or are missing, contact your dealer, distributor or courier company to have them replaced before starting this installation.

Conversion Kit Installation:

Turn the unit off by pressing the ON/OFF Key on the remote and shut off gas supply at the shut-off valve upstream of the unit. **CAUTION: The gas supply must be shut off prior to disconnecting the electrical power and before proceeding with the conversion. Allow the valve and unit to cool down to room temperature.**

- Remove Safety Screen/Surround Panel and the glass door as shown in the MAINTENANCE AND SERVICE - GLASS DOOR REMOVAL section of this manual.
- Carefully remove any media and logs.
- Remove the burner as shown in the MAINTENANCE AND SERVICE - BURNER REMOVAL section of this manual.
- Convert the existing pilot orifice with the one provided in this kit (see Figure 9) using a **7/16" wrench**. Fully unscrew and remove the pilot head and replace the orifice insert, bell end down. Re-install and tighten the pilot, if the head does not reach proper orientation in the snug position then contact your Enviro dealer.
- Convert the burner orifice:
 - Remove the main burner orifice with a 3/8" deep socket
 - Put a bead of pipe-thread sealant into the orifice mount, install orifice from kit. **DO NOT OVER-TIGHTEN.**

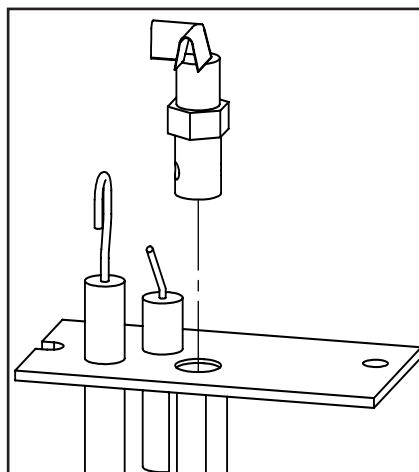

Figure 9: Pilot Orifice

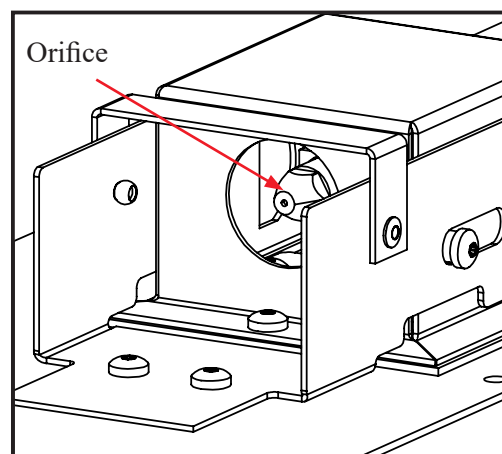

Figure 10: Orifice location

FUEL CONVERSION

7. Convert the SIT gas valve (Figure 11):

- a) Locate the gas valve directly underneath the front of the firebox and remove the existing stepper motor using a T20 screwdriver [A & B].
- b) Remove the rubber diaphragm and spring [C] within;

DO NOT REUSE.

- c) Install the new stepper motor with integrated diaphragm assembly [D & E] using the longer T20 screws supplied [F].
- d) Adhere the supplied SIT conversion label [G] to the valve body.
- e) Plug the new stepper motor into the X6 port of the IFC.

8. Reinstall the burners, log grate, burner pan media, logs set, glass door and surround (see ANNUAL MAINTENANCE, MAINTENANCE AND SERVICE sections of this manual).

9. Purge any air from gas line and reconnect to unit.

WARNING: NEVER USE AN OPEN FLAME WHEN TESTING FOR GAS LEAKS.

10. Use a small brush and apply a warm soapy water solution to all gas connections. If a gas leak is present, bubbling will occur. Gas leaks can be repaired by using a gas approved pipe thread sealant.

11. Light the pilot and recheck for leaks in the aluminum pilot line. If a leak is evident, contact your ENVIRO dealer for a pilot line replacement. **WARNING: DO NOT ATTEMPT TO FIX THIS LINE, IT MUST BE REPLACED IF DAMAGED.** The pilot should properly cover the flame sensor. See MAINTENANCE AND SERVICE - PILOT LIGHT SECTION of this manual.

12. Start the main burner and verify full range of adjustment using the remote. Confirm the inlet and manifold gas pressures are within the acceptable range using a manometer (see INITIAL INSTALLATION - GAS LINE CONNECTION AND TESTING). If this unit has been installed at an altitude higher than 2000ft (610m) it is required to de-rate the unit accordingly.

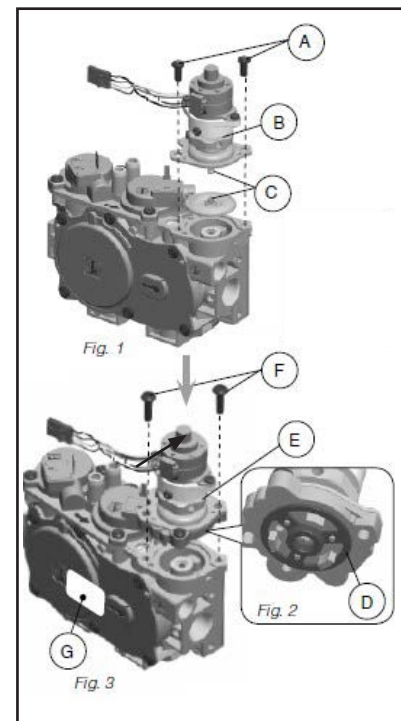

Figure 11: 885 Gas Valve

In the USA: The appliance may be installed at higher altitudes. Please refer to your American Gas Association guidelines which state: the sea level rated input of Gas Designed Appliances installed at elevations above 2000 (610 m) feet is to be reduced 4% for each 1000 feet (305 m) above sea level. Refer also to local authorities or codes which have jurisdiction in your area regarding the de-rate guidelines.

In Canada: When the appliance is installed at elevations above 4500 feet (1372 m), the certified high altitude rating shall be reduced at the rate of 4% for each additional 1000 feet (305 m).

13. MAKE SURE that the conversion label is installed on or close to the rating label to signify that the unit has been converted to a different fuel type.

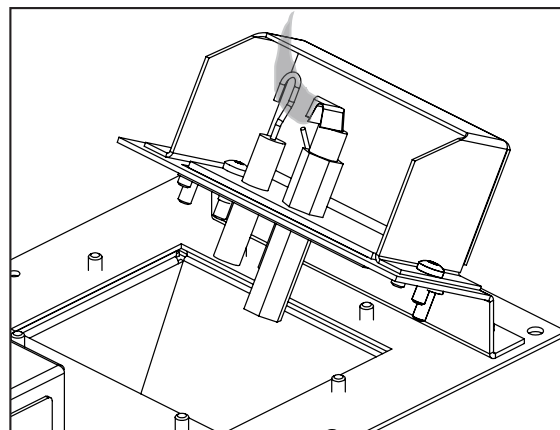

Figure 12: Flame Sensor Coverage

INITIAL INSTALLATION

QUALIFIED INSTALLERS ONLY

INTRODUCTION:

This section of the owner's manual is for the use of qualified technicians only. Fireplace placement, hearths, facing, mantels, and venting terminations will be covered, as well as the gas and electric systems. There are several installation safety guidelines that must be adhered to. Please carefully read the safety precautions at the front of this manual.

- Remove the packaging from the appliance, and check to make sure there is no damage. If damage is found, please report it to both the carrier and your dealer as soon as possible.
- Locate a position where the flue system of the stove can be properly installed without damaging the integrity of the building; e.g. cutting a wall or ceiling joist.
- Check stove and flue system clearance requirements.
- Locate the stove in a position so a gas supply line can be run to it.
- The fireplace may need an electrical connection depending on the options added.
- Locate the stove in a large and open room that is centrally located in the house. This will optimize heat circulation and comfort.
- The flow of combustion and ventilation air must not be obstructed.

UNIT INSTALL PREPARATION:

Take a minute to familiarize yourself with Figure 13 below.

- The top framing standoffs will need to be folded up and secured with a T-20 screws on top and side of the cabinets, This can be seen in Figure 13.
- The side framing standoffs for this unit also double as handles for positioning and lifting.
- The nailing flanges secure the unit to the framing, these can be turned 180 to allow for a 1/2in shallower

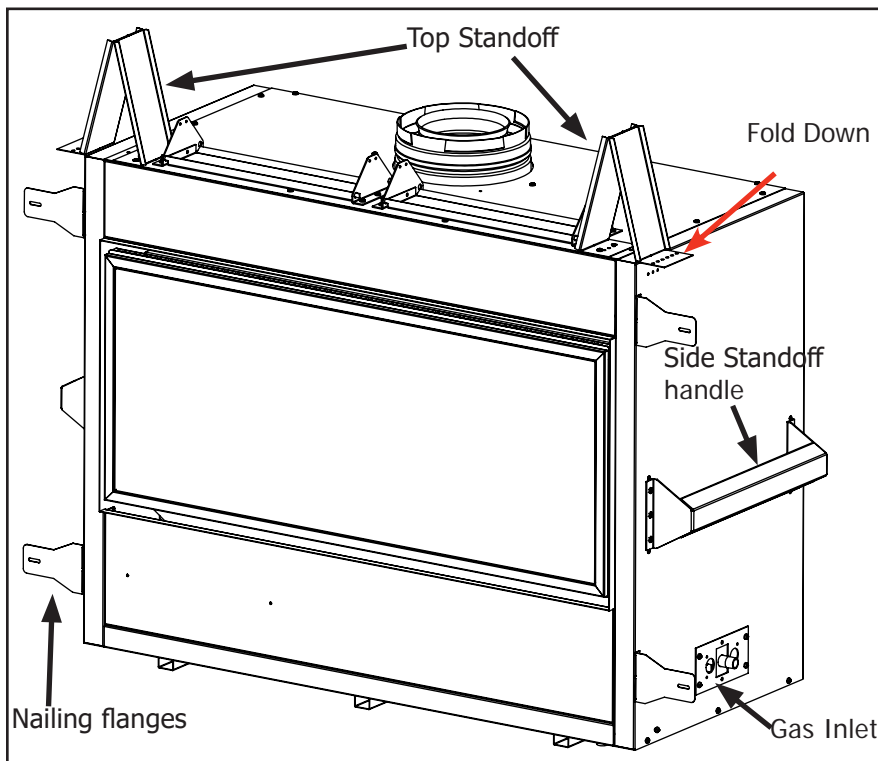

Figure 13: Fireplace Installation Prep. - 1

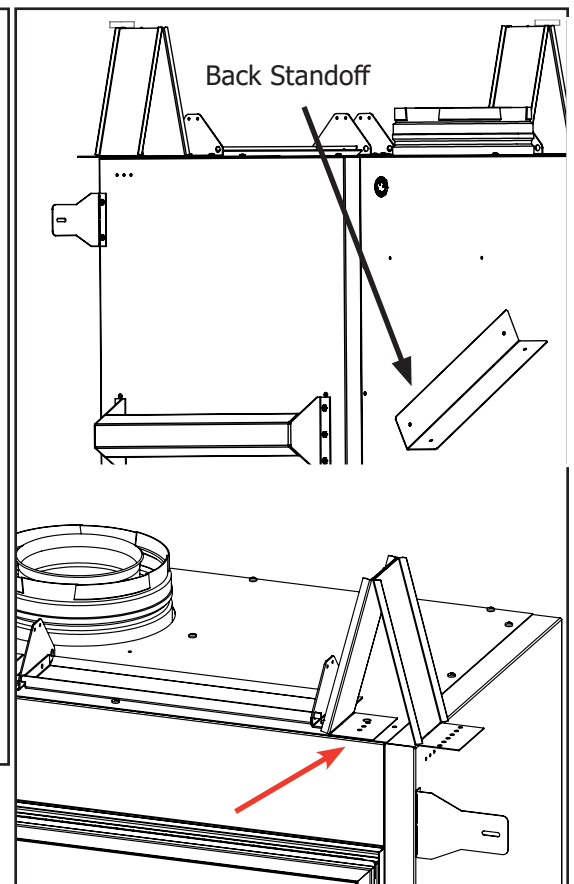

Figure 14: Fireplace Installation Prep. - 2

INITIAL INSTALLATION

QUALIFIED INSTALLERS ONLY

STEEL STUD:

Framing of the fireplace requires a steel stud placed above the unit. The steel stud included with the fireplace comes in two pieces that combine to create a telescopic steel stud. This allows for horizontal adjustment to fit the specific length of your unit.

1. Take the two steel stud pieces and slid them into each other. The flanges of each piece should be at the end of the assembly, as well as facing upwards as shown in Figure 15.
2. Place the steel stud onto the top standoffs and slide outwards until both ends make contact with the framing studs (see Figure 16).

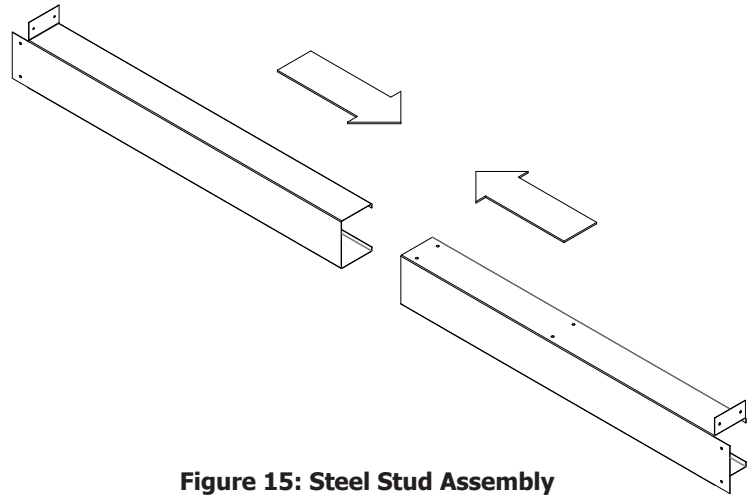

Figure 15: Steel Stud Assembly

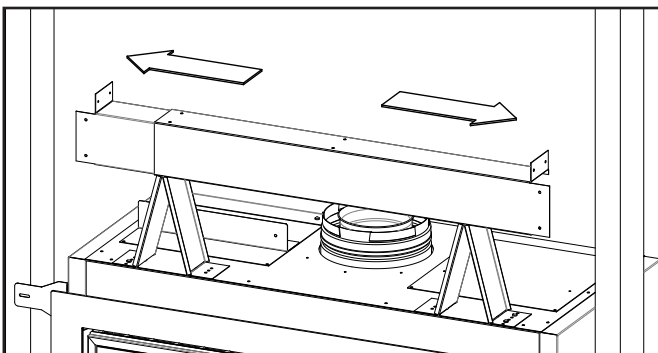

Figure 16: Steel Stud Placement

3. Using the provided sheetmetal screws, attach the two steel stud pieces together using the labeled holes in Figure 17. This should be done on the top and bottom of the steel stud to ensure its rigidity.
4. Attach the steel stud to the framing studs using the holes shown in Figure 18.

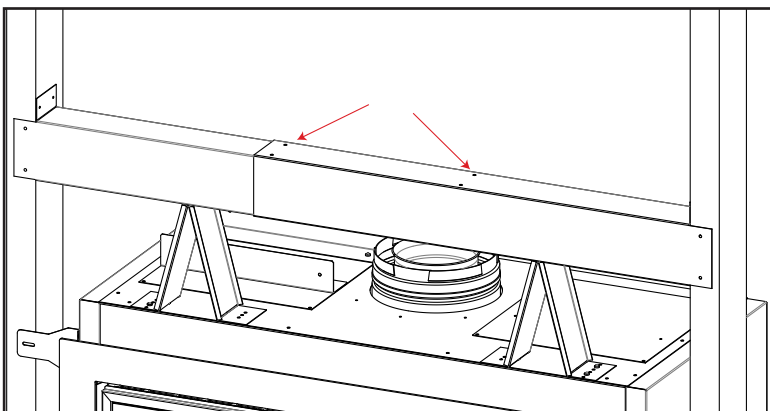

Figure 17: Steel Stud Installation

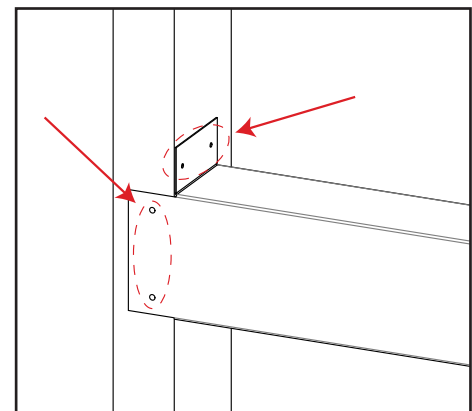

Figure 18: Steel Stud Framing Attachment

INITIAL INSTALLATION

QUALIFIED INSTALLERS ONLY

PLACEMENT AND FRAMING:

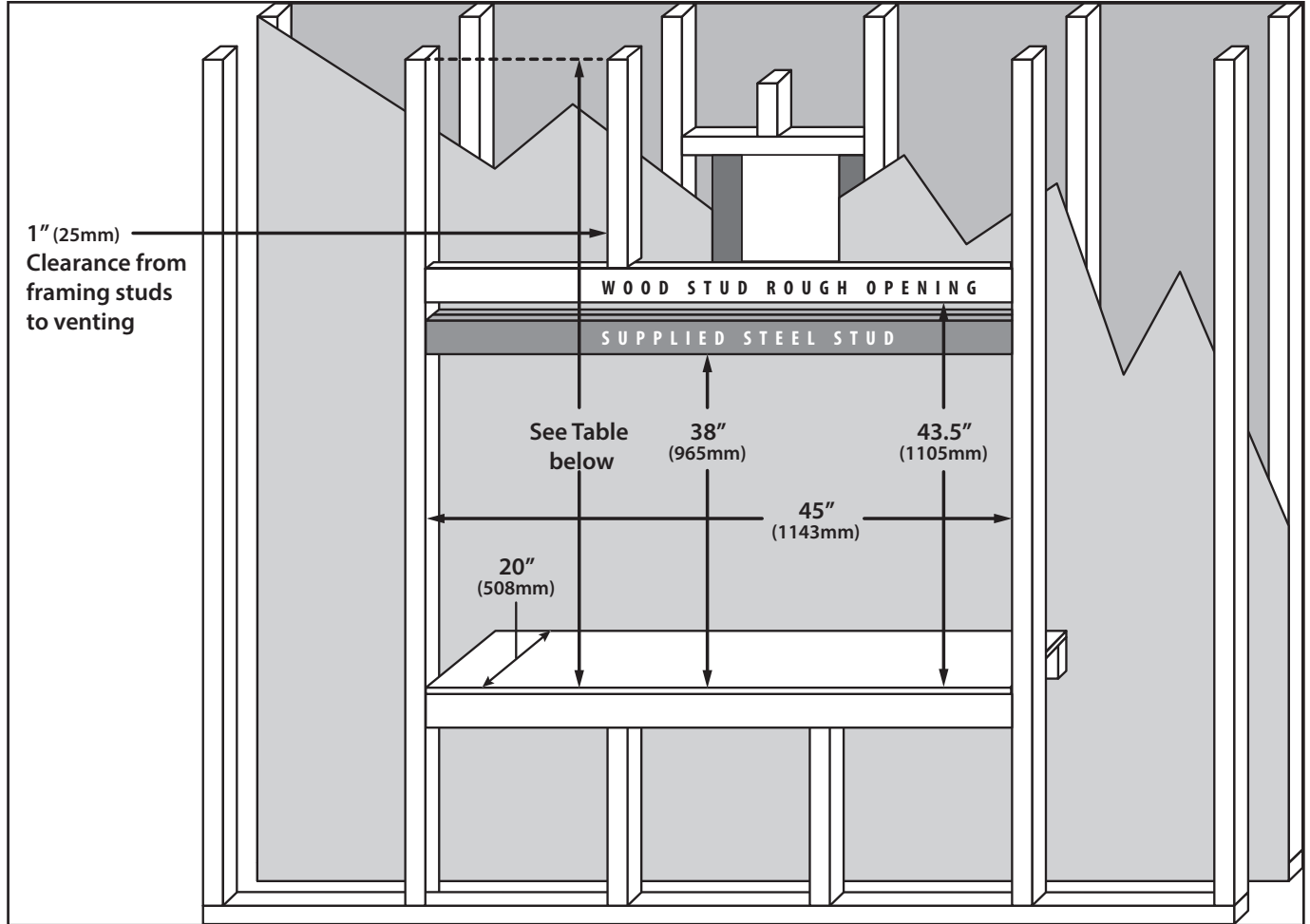

Figure 19: Construction Framing Dimensions

Table 2. Framing Dimensions.

Minimum Enclosure Ceiling Heights		
No CSS Activated	65"	1651mm
Front Vent CSS Kit (50-4128)	80"	2030mm
Side Vent CSS Kit (50-3455)	82"	2083mm
CSS Activated (Non-Ducted)	96"	2438mm

The location for the fireplace can be raised, at floor level, or installed in a corner. There are specific framing measurements for each situation. The basic rough opening should have the dimensions shown in Figure 19. The fireplace must have a strong and level surface to be placed on. The surface should be made of wood or a non-combustible material.

The gas line should be run to the right side of the fireplace, there is a 3/8 Male NPT fitting to connect the gas line too. The electrical wiring should be brought to the left side if needed. The location of the fireplace should be chosen so there will be at least **36 inches (91.4 cm)** from drapes, doors and other combustibles.

INITIAL INSTALLATION

QUALIFIED INSTALLERS ONLY

CLEARANCES & NON-COMBUSTIBLE :

When installing the C34I as a zero clearance fireplace the correct clearances and materials must be used:

ABOVE UNIT: A minimum **13 3/4" (350mm)** of non-combustible facing material must be used above the firebox opening.

IN FRONT OF UNIT: The C34I can be placed on a combustible floor if desired. The unit cannot sit directly on combustible flooring other than wood.

ADJACENT/SIDEWALL: A minimum of **5 3/16" (132mm)** of non-combustible facing materials must be used of the side of the firebox opening above the bottom edge opening. There must be a minimum distance of **7" (229mm)** from the finishing edge of the C34I to an adjacent wall composed of combustible material.

MANTLE: It is not necessary to install a mantle, but if one is desired the guidelines as shown on page 30. The minimum clearance from the side of a mantle to wall is 4".

FLOOR: There must be a minimum distance of **10" (254mm)** from the bottom finishing edge of the C34I to a floor composed of combustible material.

CRACKING: The most common area of cracking is along the horizontal cement board/drywall transition; placing this transition further away from the heat will help prevent cracks. If you have concerns of excessive finishing wall temperature follow one of these options to minimize the possibility of cracking:

1. Activate / install one of the Cool Surface System (CSS) options.
2. Install concrete board higher than the minimum specified dimension.
3. Add a decorative tile trim over the drywall transition area.

See "Finishing the Fireplace" section of the manual for further information.

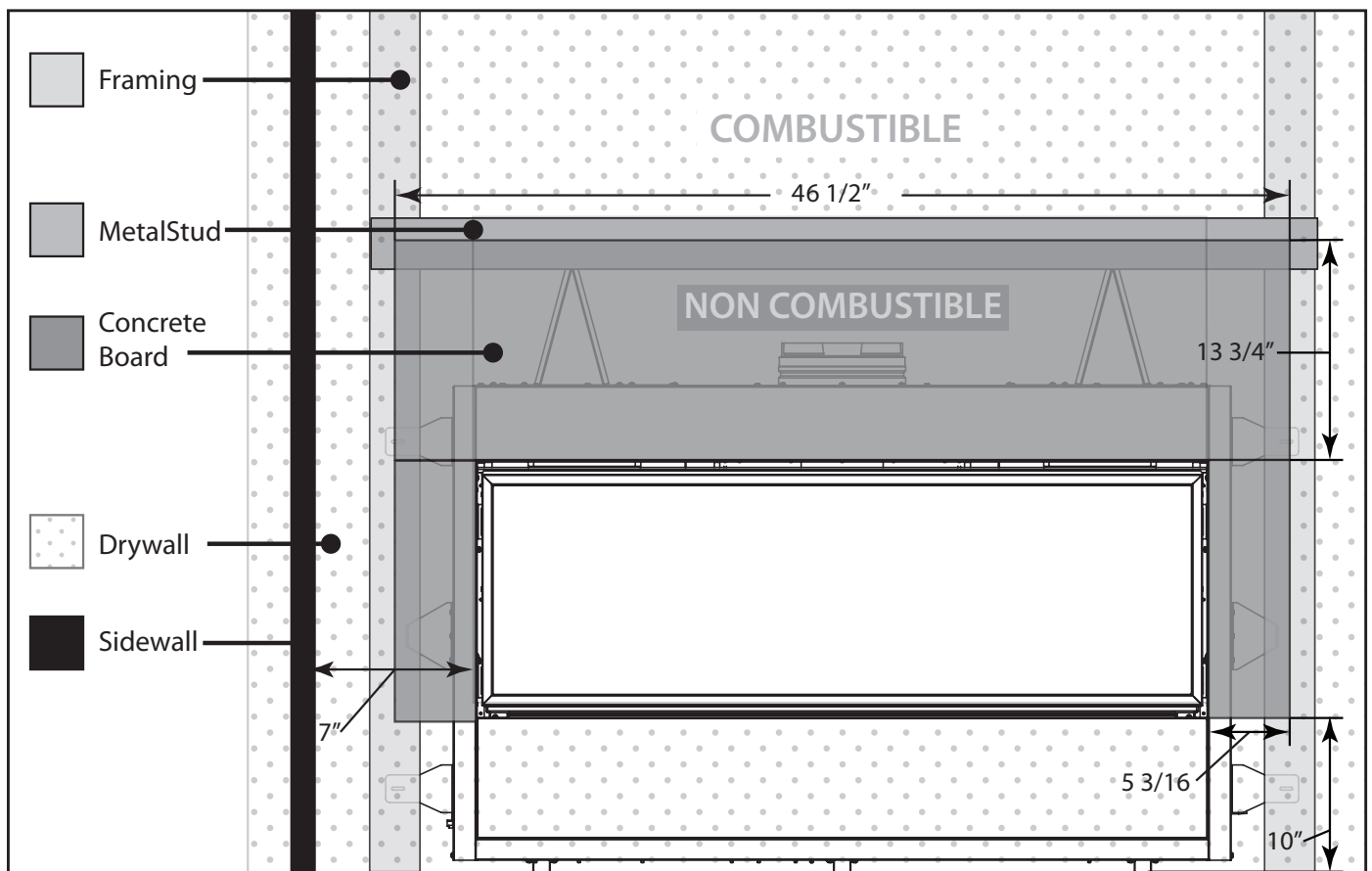

Figure 20: Finishing Non-Combustible Zone

INITIAL INSTALLATION

QUALIFIED INSTALLERS ONLY

COOL SURFACE ACTIVATION

WARNING: IT IS ESSENTIAL THAT THE CHASE IS VENTED IN A MANNER THAT RELIEVES THE ADDITIONAL HEAT ENTERING THE CHASE. ENSURE ONE OF THE AVAILABLE FRAMING OPTIONS HAVE BEEN CONSTRUCTED IN ACCORDANCE WITH THIS MANUAL. FAILURE TO DO SO CAN CREATE AN OVERHEATING SITUATION THAT COULD LEAD TO BUILDING FIRE.

Ensure your chase has been constructed in a manner that vents the chase into the same room. It is not permitted to vent the chase into an adjoining room. The CSS bleeds heat off the appliance into the chase as opposed to climbing up the front face. This dramatically lowers the front wall temperatures allowing the placement of delicate objects above the appliance. Review the guidelines in the previous sections to ensure your install is in accordance with the framing specifications. Follow these instructions to activate the CSS feature.

Note: Dual Convection Fan Kit May not be used in conjunction with CSS.

1. Remove the safety screen (see section "Safety Screen" on page 11).
2. Remove and **discard** the top Discharge Accelerator from above the door glass. Simply lift up to disengage from the slotted screws.
3. There is a CSS cover on the inner top of the cabinet that must be removed. It is attached using #8 T20 screw. Remove these screws and remove the cover (see Figures 21 & 22).
4. On the top of the unit you will find two hinge assemblies that must be opened. Remove the #8 T20 screws found preattached on the hinge brackets.
5. Rotate the CSS Flaps up so the pre punched holes align where the screws from the previous step were removed. Reattach the screws to hold the plates in place (see Figure 23-24).
6. The CSS is now activated. Reattach the safety screen and proceed with installation.

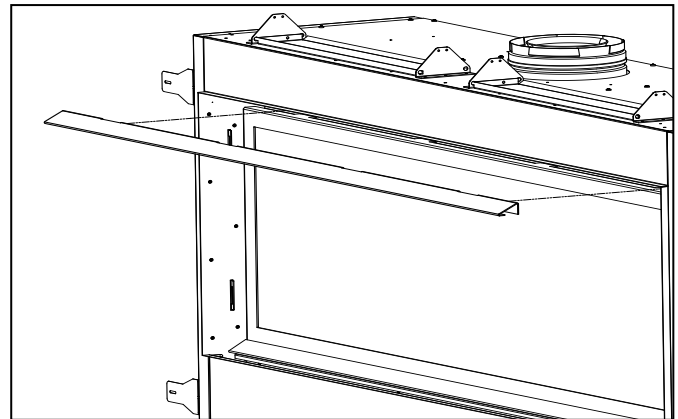

Figure 21: Discharge Accelerator removal

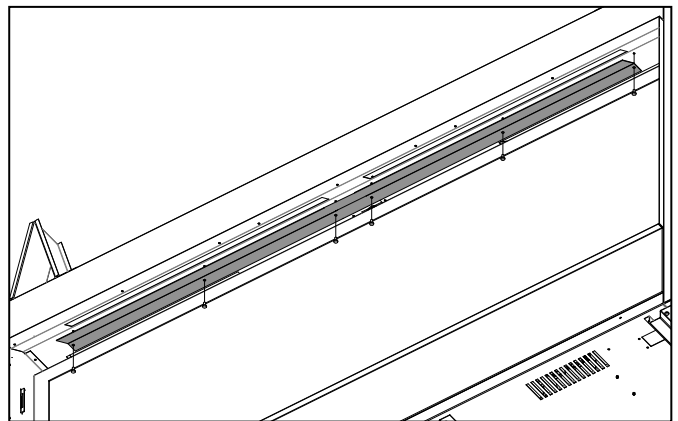

Figure 22: CSS cover removal

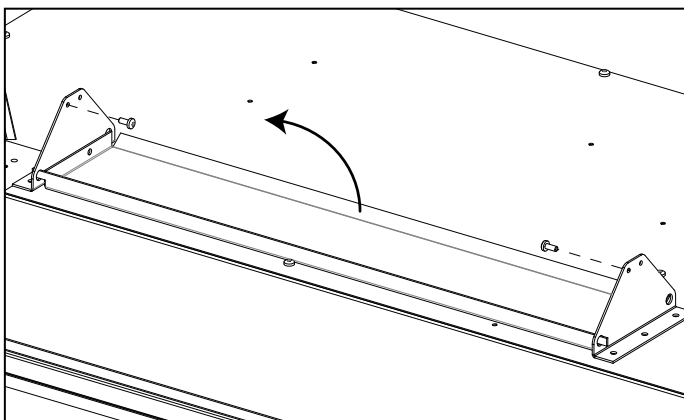

Figure 23: CSS flaps - closed

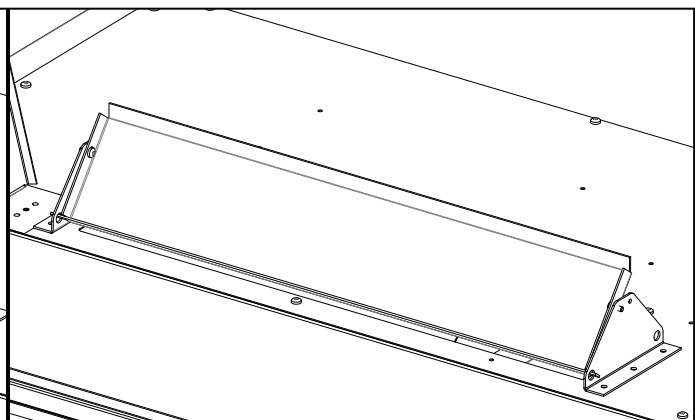

Figure 24: CSS flaps - open

INITIAL INSTALLATION

QUALIFIED INSTALLERS ONLY

COOL SURFACE SYSTEM FIREPLACE CONVERSION - DUCTED

This fireplace may also be converted to use the optional ducted Front Vent (50-4128) or Side Vent (50-3455) CSS kits for installations where a lower ceiling height is required or different finished appearance is desired. Prior to framing, the top of the fireplace cabinet must be converted as described in the following steps.

1. Using a drill and a Torx T20 driver bit, remove the 2 CSS Flap assemblies (6 pieces, 8 screws total) from the top of the cabinet as shown. Retain the screws for the next step and discard the CSS Flap assemblies.

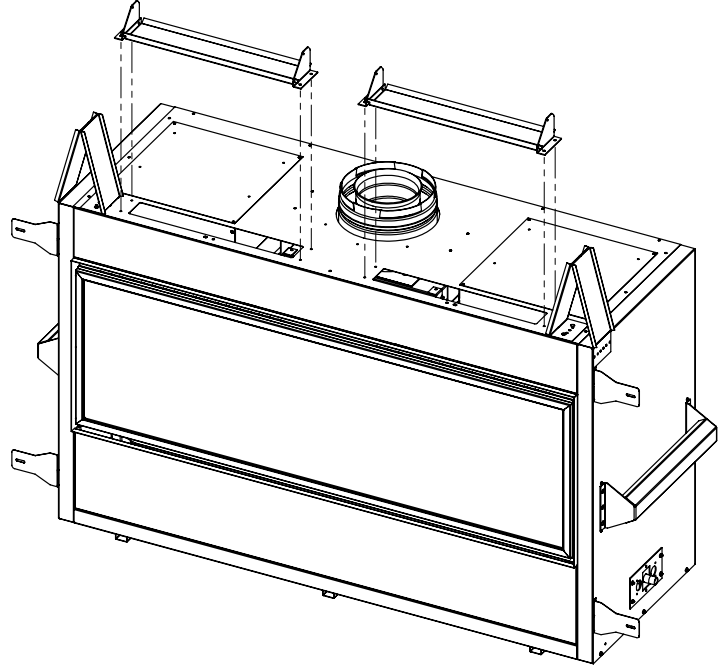

Figure 25: CSS flaps - Removal

2. Install the 2 top CSS Cover Plates and additional screws supplied with the fireplace, as shown, using 6 screws per plate (12 total).

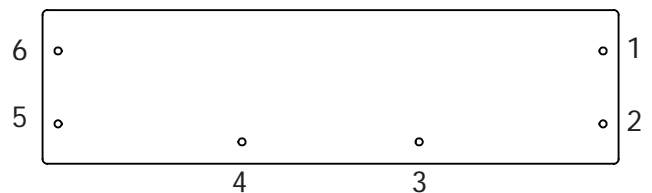
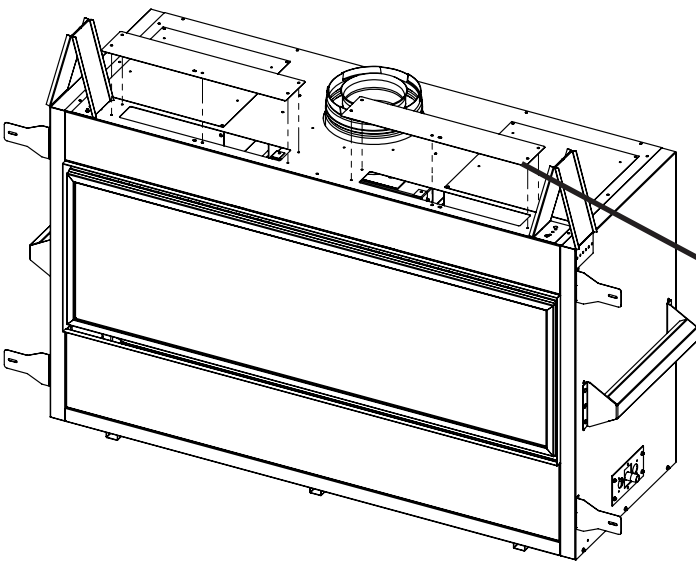

Figure 26: CSS Top Cover Plates

INITIAL INSTALLATION

QUALIFIED INSTALLERS ONLY

3: Next, remove the inner and outer cover plates from the fireplace as shown below. Each cover plate has 4 mounting screws. Both sets of cover plates are no longer required and can be discarded. Retain 8 of the removed mounting screws to secure the duct collars.

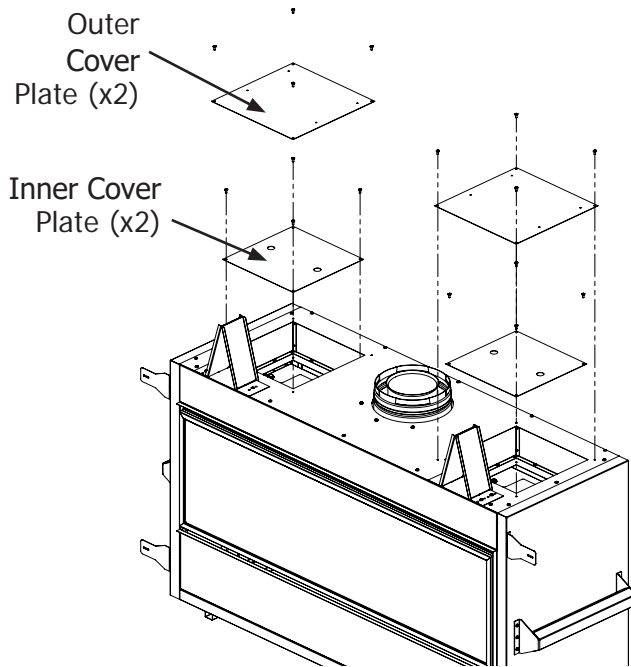

Figure 27: CSS Duct Cover Plates

4: Attach the 2 duct collars supplied in the Front or Side Vent CSS kits to the top of the cabinet as shown below. Secure the collars by re-using the 8 screws saved in the previous step.

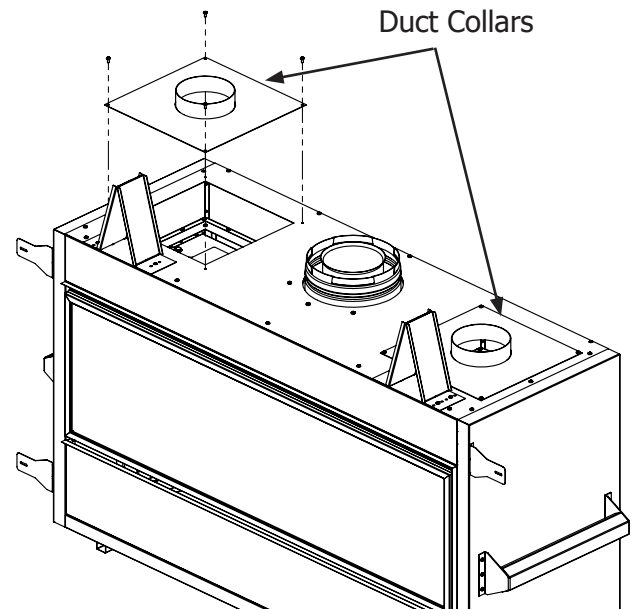

Figure 28: CSS Duct Collar Plates

5: Attach the 2 piece Combustible Facing Kit supplied in the Front or Side Vent CSS kits to the top front of the cabinet as shown below. The top standoffs will need to be briefly unfolded to install the 2 outside mounting screws. The fireplace is now fully converted and ready for installation. Refer to the installation manuals of the Front Vent (50-4128) or Side Vent (50-3455) CSS kits for more detailed information, requirements, clearances and finishing steps.

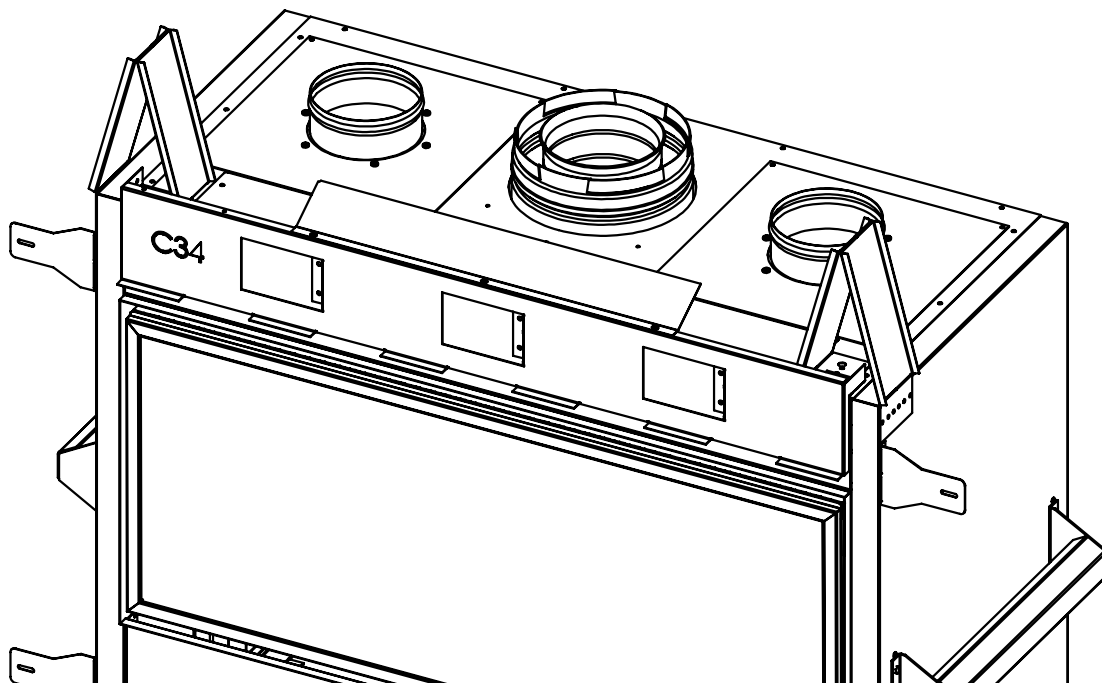

Figure 29: CSS Combustible Facing Kit

INITIAL INSTALLATION

FINISHING THE FIREPLACE:

QUALIFIED INSTALLERS ONLY

If the CSS has NOT been activated / installed you MUST use a non-combustible material directly above the fireplace extending up the front wall 13 3/4" from the top finishing edge. Combustible material must NOT be brought up to the top finishing edge and CANNOT overlap the non-combustible board. Wall boards / panels used above the fireplace in the non-combustible zone must comply with ASTM E136 or similar standard as a fully rated non-combustible material. Cement boards and other products that are not correctly rated may create odours / smells once the fireplace has been in operation for a prolonged period of time. Products such as PermaBASE are not recommended for use above this fireplace. **Surface temperatures above the fireplace in excess of 300°F / 149°C should be expected** and all finishing materials i.e. adhesive, mortar, sealants etc. must be rated for prolonged exposure at this temperature or higher. For a smooth, non-combustible wall finish products from Promat or Skamol are strongly recommended.

Recommended Method of Wall Board Installation - The wall board of choice should be mechanically fastened to the framing around the perimeter of the fireplace and NOT to the fireplace chassis. The board should be floated across the top of the opening, uncoupled from the fireplace to allow for expansion and contraction during heating and cooling. This will greatly reduce the potential of cracking material.

Stone Slab / Face Installation - To reduce the potential of cracking, stone slabs should be split into 3 pieces (Left, Middle, Right) with the middle spanning across the full width. Single piece slabs are not recommended and may develop cracks over time in the corners.

Sherwood Industries is not liable for any discolouring, cracking or flaking that may occur in the stone finish.

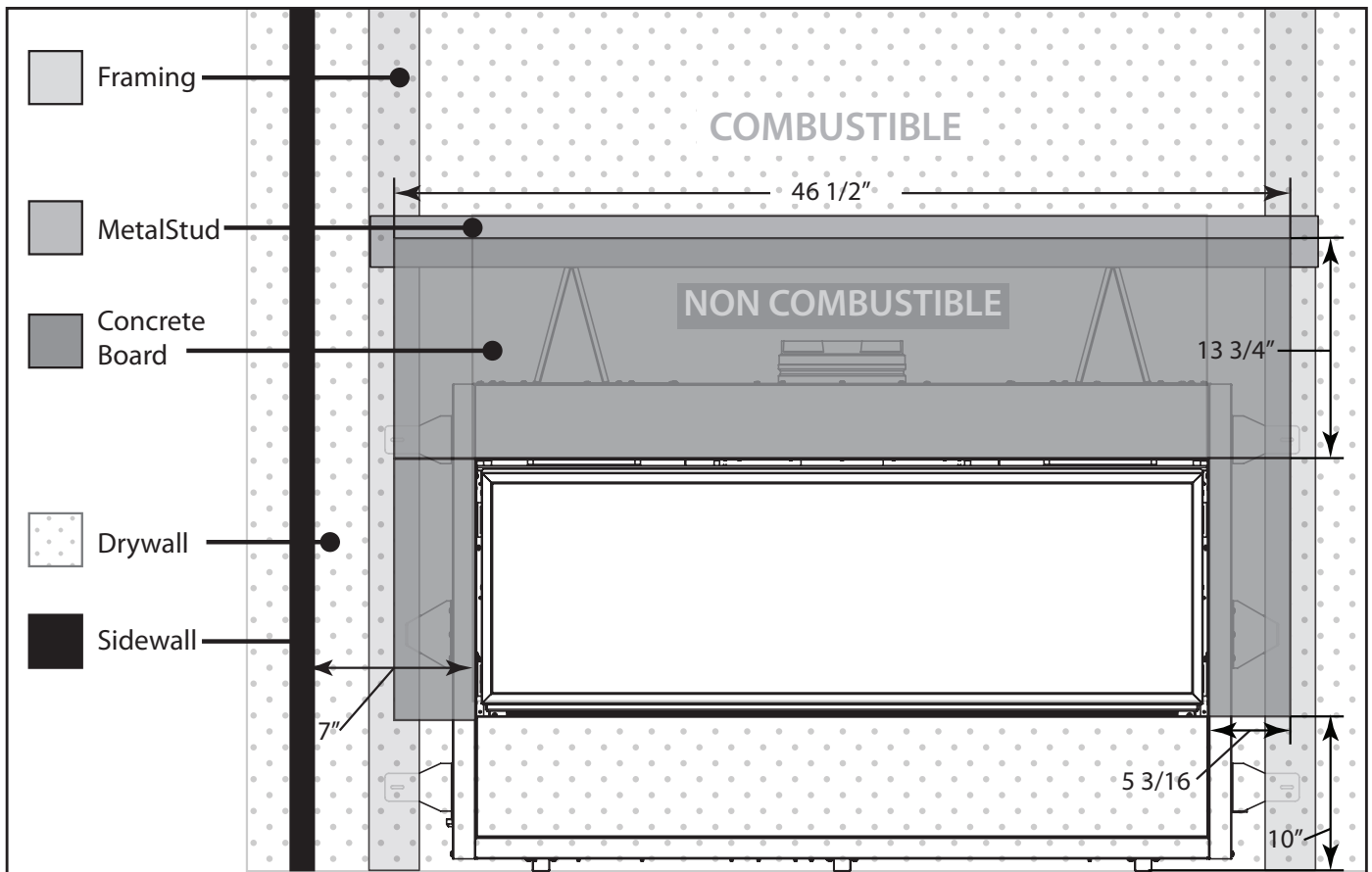

Figure 30: Non-Combustible Zones

INITIAL INSTALLATION

QUALIFIED INSTALLERS ONLY

Combustible material may be brought up to any finishing edge ONLY if the Cool Surface System (CSS) has been correctly activated / installed allowing heat in the chase to be vented. This system keeps the front wall cool enough for any combustible materials. Non-combustible board can still be used but is not mandatory when the CSS has been used, combustible material may overlap in this situation.

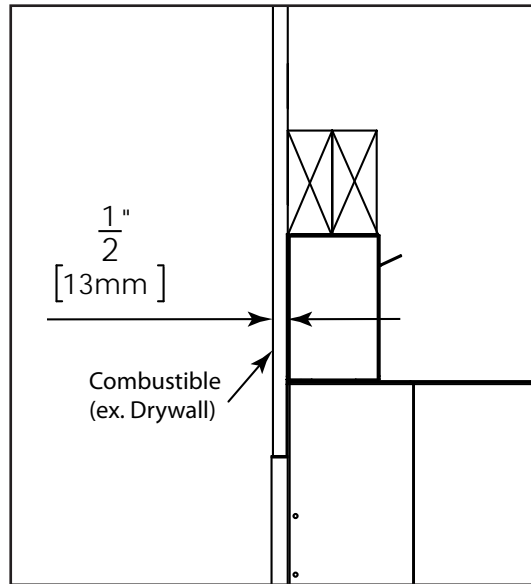

Figure 31: Combustible Wall Material

First Fire & Curing - When the unit is turned on for the first time, it should be turned onto high without the fan on (if equipped) for the first 4 hours. This will begin to cure the paint, logs (if installed), gasket material and other products used in the manufacturing process. This process may take upwards of 10+ hours until the fireplace is cured to an acceptable level. It is advisable to open a window or door, as the unit will start to smoke and can irritate some people. After the unit has gone through the first burn, turn the unit off including the pilot, let the unit get cold then remove the glass door and clean it with a good gas fireplace glass cleaner, available at your local ENVIRO dealer.

INITIAL INSTALLATION

QUALIFIED INSTALLERS ONLY

COOL SURFACE SYSTEM FRAMING & FINISHING - NON-DUCTED

This appliance is manufactured with a built-in heat distribution kit, referred to as the Cool Surface System (CSS). The purpose of the CSS is to dramatically reduce the front wall temperatures above your appliance. This is very useful when delicate objects such as a TV or artwork are mounted above the unit. Using this feature will also allow you to use combustible facing materials right up to the finishing edge. It is extremely important these instructions are followed meticulously. If not installed correctly this could be very dangerous and could lead to building fire. If the CSS is activated it is crucial that the chase is vented in accordance to this manual.

When the CSS is activated, it is not longer required to install a non-combustible board above the fireplace. The CSS also reduces the minimum height when installing mantels (see section "Mantel Requirements" on page 30). For CSS activation instructions, refer to section "Cool Surface Activation" on page 20.

IMPORTANT - Installations with an activated Non-Ducted CSS require a **minimum 96" ceiling height**, see page 18 for more information.

FRONT OPENING - NON-DUCTED:

Construct the framing in a way that provides a minimum 39 inch (991mm) by 2 inch (50.8mm) gap at the top of the facing wall, see figure below. It is essential that these dimensions are respected and not deviated away from them when using combustible materials inside the chase.

- Front CSS openings must be at least 60" (152cm) away from the nearest fire sprinkler head.
- A wall directly in front of front CSS opening must be at least 24" (406mm) away.

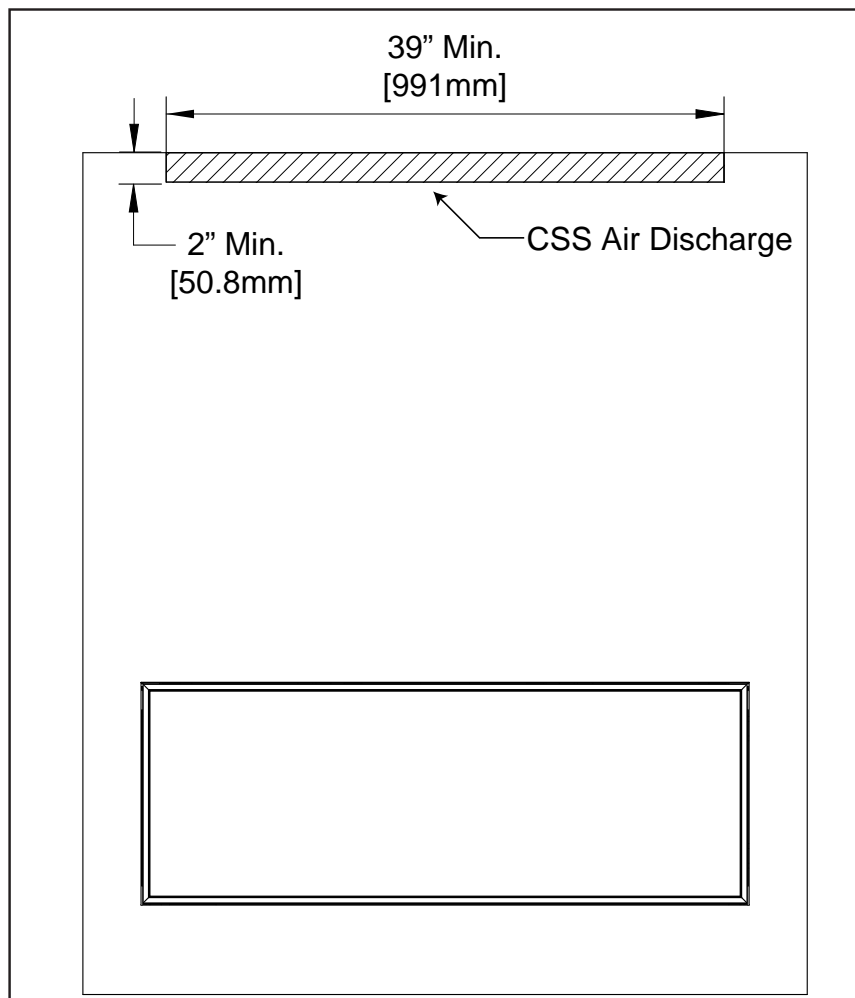

Figure 32: CSS Front Outlet

INITIAL INSTALLATION

QUALIFIED INSTALLERS ONLY

SIDE OPENING - NON-DUCTED:

The framing can also be constructed in a way that provides two side vents as shown in Figure 33. The size of the side vents must provide a minimum area equal to the area provided by the front CSS discharge in Figure 32 (i.e. 2in x 39in = 78 in²).

- Side CSS openings must be a minimum 13" (33 cm) wide.
- Side CSS openings must be at least 60" (152 cm) away from the nearest fire sprinkler head.
- A wall directly in front of any side CSS opening must be at least 16" (406mm) away

For example: If you want a side vent with a height of 3", the minimum width of each side vent would be:

$$2 \times (\text{Height} \times \text{Width}) = 78 \text{ in}^2$$

$$2 \times (3\text{in} \times \text{Width}) = 78 \text{ in}^2$$

$$\text{Width} = 13 \text{ in}$$

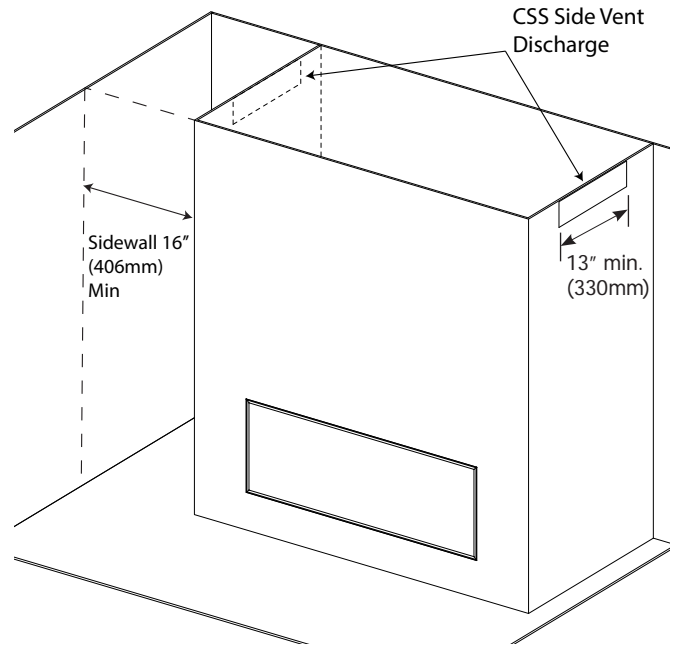

Figure 33: CSS Side Vent

FALSE CEILING - NON-DUCTED:

If your ceiling dimension is greater than the minimum requirement you may want the CSS Air discharge lower on the wall. To do this a false ceiling is required to properly evacuate the heat from the chase (figures 34 & 35).

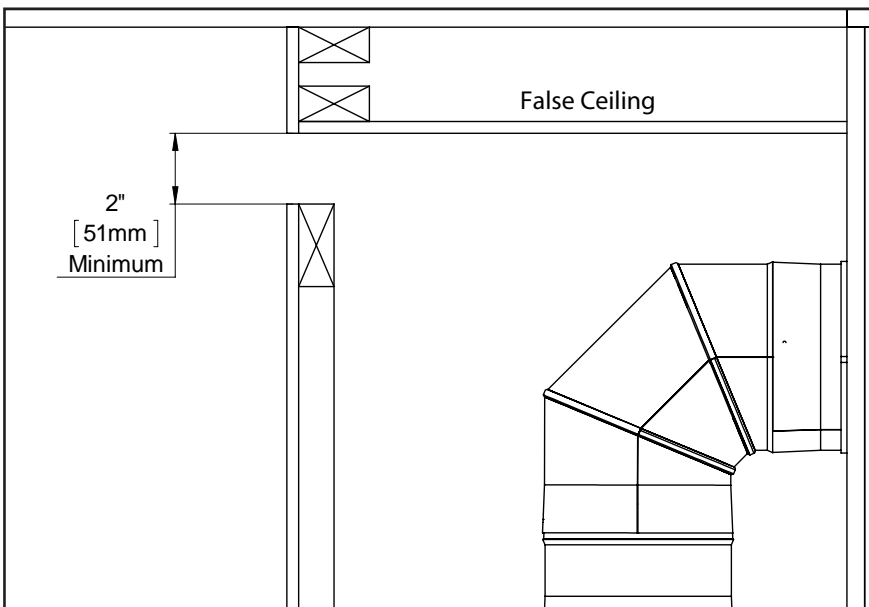

Figure 34: False Ceiling

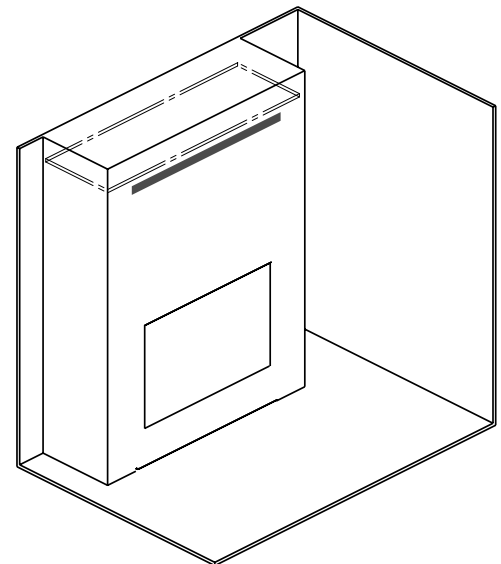

Figure 35: False Ceiling Iso View

INITIAL INSTALLATION

QUALIFIED INSTALLERS ONLY

OPEN CHASE - NON-DUCTED:

This could be considered the most discreet option when considering the CSS. The chase must be constructed in a way that stops short of the ceiling, leaving it totally vented above. Minimum framing dimensions must be followed when constructing this option and not to deviated from them when using combustible materials.

Note - Chase cannot be open to joists or rafters above.

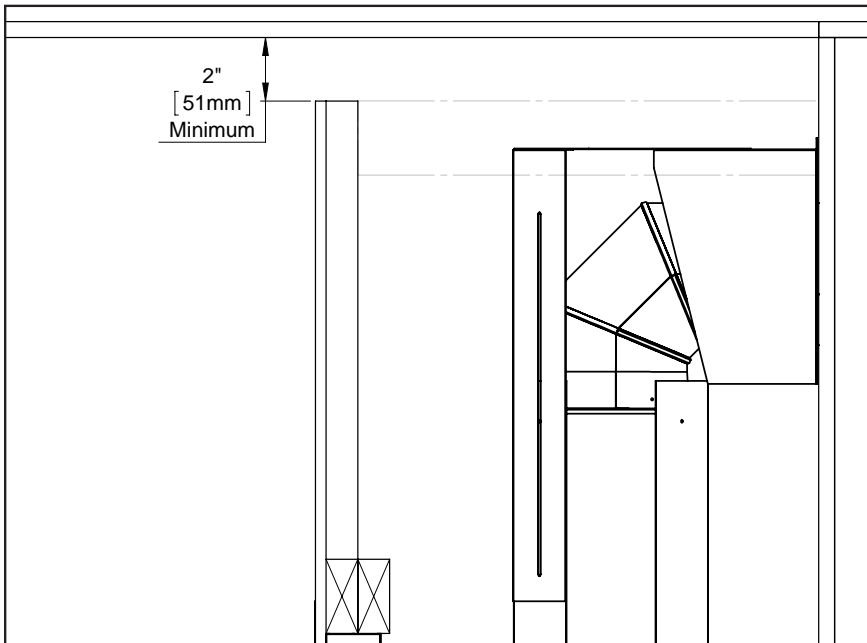

Figure 36: Open Chase

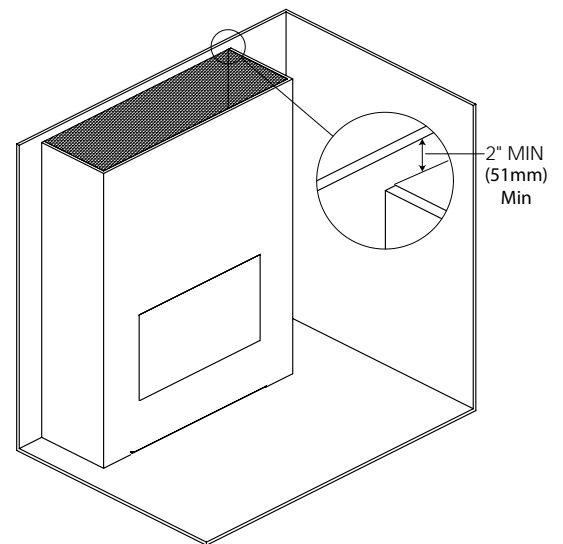

Figure 37: Open Chase Iso View

CSS REQUIRED VENT HEAT SHIELDS - NON-DUCTED:

The C34 fireplace is supplied with a vent heat shields that are mandatory for all installations.

Note: Only install the thimble Shield if you intend to activate the built in Cool Surface System (CSS)

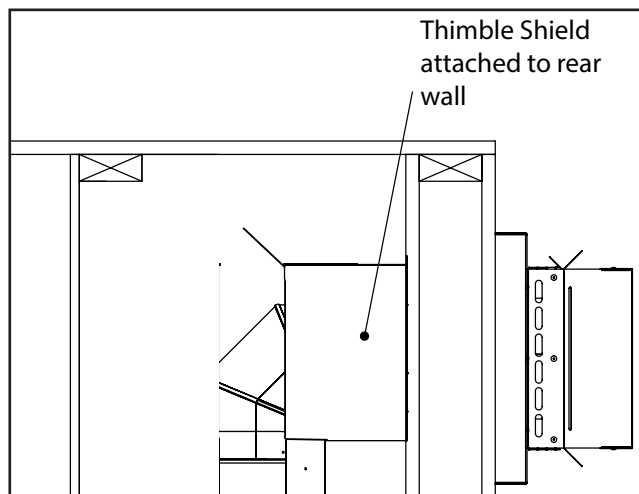

Figure 38: CSS Heat Shield

INITIAL INSTALLATION

QUALIFIED INSTALLERS ONLY

CSS: TV INSTALLATION CONSIDERATIONS:

If you are planning to mount a TV above your fireplace some considerations must be made to ensure it is protected from the heat.

During testing temperatures did not exceed 121°F (49°C) midway up the front wall (Figure 39 & Figure 40). There is no guarantee that these temperatures will not harm the longevity of your TV. Make sure to consult your TV manufacturer's specifications to find the maximum allowable operating temperature. Since every home and installation is unique, temperatures should be verified at the time of install if possible. If desired, front wall temperatures can be lowered to 104°F (40°C) with the use of a mantle (Figure 40). Refer to page 31 for revised mantle clearances. A TV should not be installed if temperatures exceed the manufacturers maximum allowable temperature.

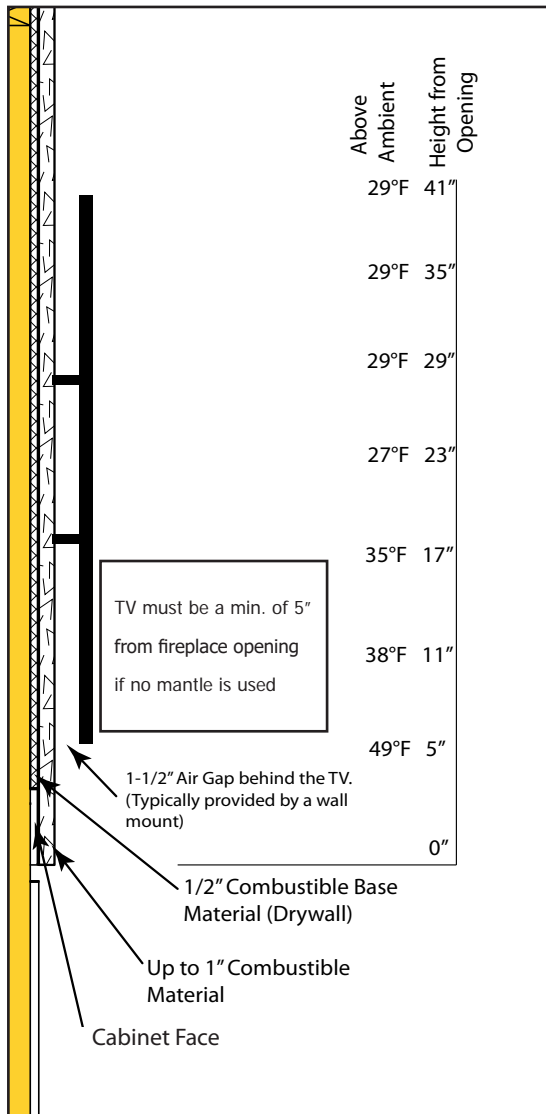

Figure 39: CSS TV Clearances

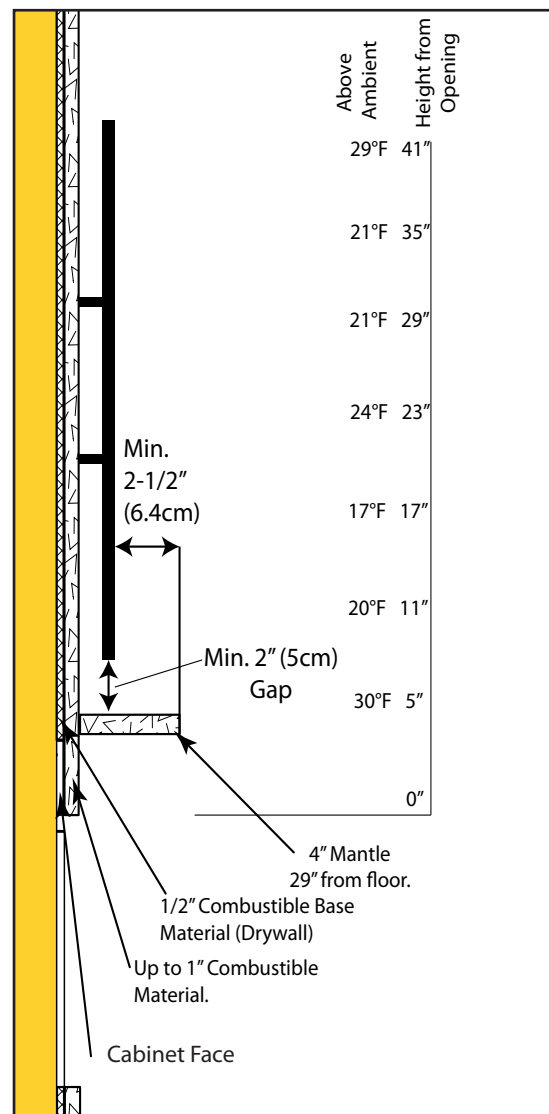

Figure 40: CSS TV Clearances

INITIAL INSTALLATION

QUALIFIED INSTALLERS ONLY

ALTERNATE GAS INLET LOCATION:

The gas inlet location can be moved to the bottom of the cabinet if needed. This may be needed for certain installations. First remove the two screws on the left side of the unit, see Figure 41. The gas inlet assembly will now be loose in the cabinet. Disconnect the gas line coming from the gas valve, the straight fitting the gas line was connected too will be replaced by a elbow supplied in the manual bag. Thread the elbow into the shut off valve, use gas sealant of threads. Mount the assembly to bottom of the firebox as shown, screws come installed in firebox. Reconnect the gas line to the elbow.

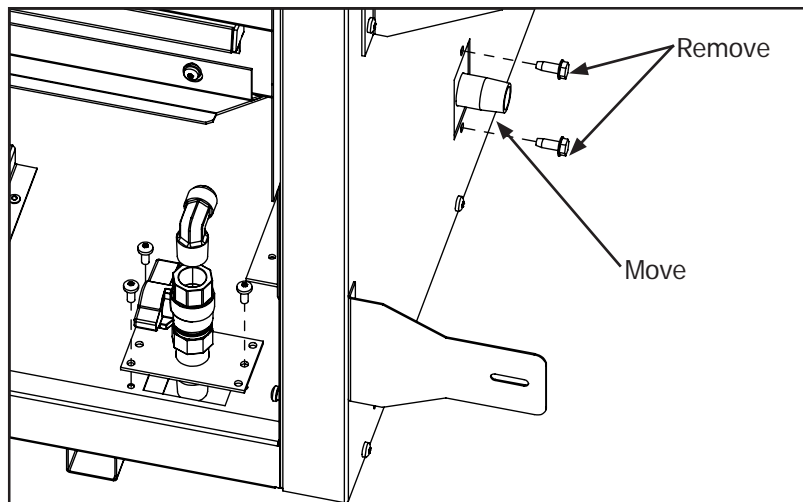

Figure 41: Alternate Gas Inlet Location

VENT TERMINATION FRAMING:

Minimum venting is shown in figure 42. the framing height to the center of the thimble is 50". Minimum venting must include a 12" vertical section and a 90 degree elbow which is then terminated horizontally.

For a vertical termination please follow the vent pipe manufacturer's installation instructions for vertical vent termination framing.

A minimum of 1 in. (25 mm) clearance on all sides of the vertical vent pipe must be maintained.

For every 12" of horizontal run there must be a 1/4" of rise.

1" of clearance between framing and venting must be maintained at all times. 2" above the venting and 3" above an elbow.

Please see vent cap clearance in page 35. Also refer to local building and fire codes.

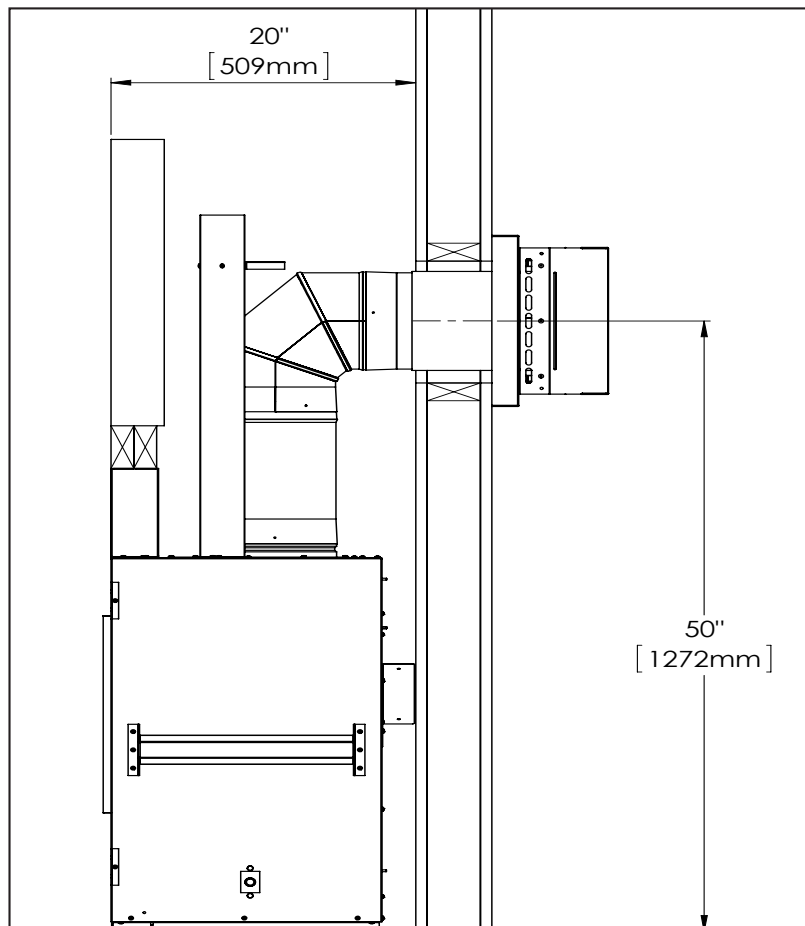

Figure 42: Minimum Horizontal Venting

INITIAL INSTALLATION

QUALIFIED INSTALLERS ONLY

FLOOR PROTECTION:

The C34I may be installed on a combustible floor. **If the appliance is to be installed directly on carpeting, tile, or other combustible material other than wood flooring, the appliance must be installed on a metal or wood panel extending the full width and depth of the appliance.**

If masonry is to be used, prepare the necessary foundation for the masonry load. When masonry construction is being used, a lintel must be used over top of fireplace to support the added weight.

Consider the height of hearth finish material (stone, brick, etc.) when building a fireplace platform. The bottom of the fireplace must be level with finished hearth.

Build the hearth to desired size and height. If a hearth extension is desired, combustible material may be used.

Above floor level installations: A solid, continuous platform must be constructed below the appliance. MINIMUM PLATFORM SIZE: 45 in. (1143 mm) wide x 20 in. (508 mm) deep.

NON-COMBUSTIBLE PLATFORM

A platform built from all non-combustible materials may be constructed in front of the unit. A 1" clearance from the bottom tiling flange must be maintained. Refer to the dimensions in Figure 43.

Note - A surround panel cannot be used with a platform built at minimum clearance.

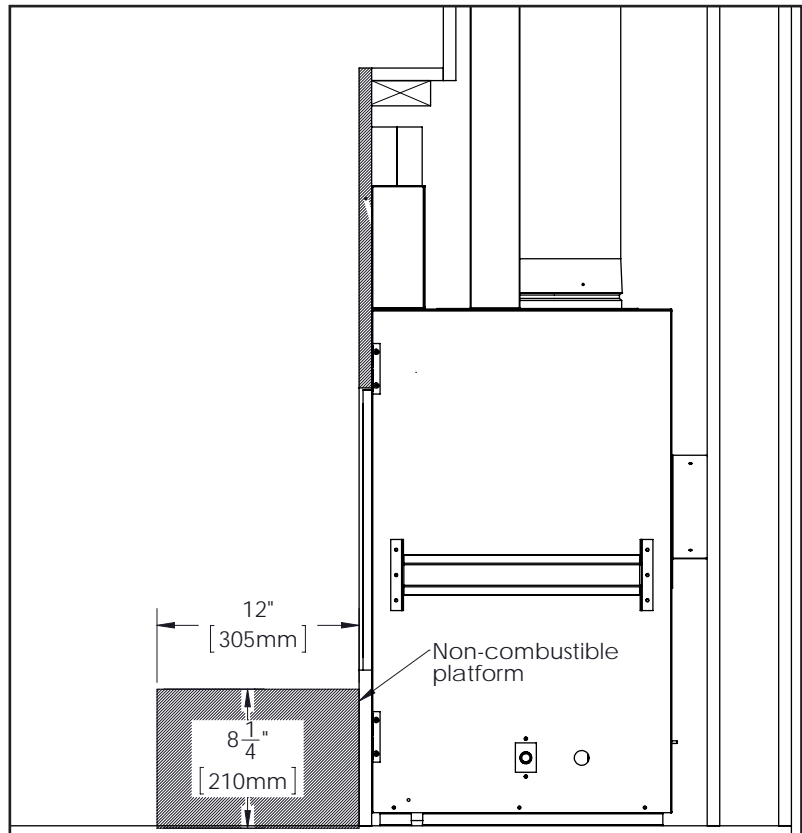

Figure 43: Non-Combustible Platform

MANTEL REQUIREMENTS:

Refer to Figure 44 for a combustible mantel installation, measurement is from bottom of the unit to the bottom of the mantel. See Figure 46 for more clarity. The mantel height is drastically reduced when the CSS is activated. Refer to Figure 45 if the CSS is activated.

If you are planning on installing a TV above the fireplace refer to page 28 & 36 to see the options available.

INITIAL INSTALLATION

QUALIFIED INSTALLERS ONLY

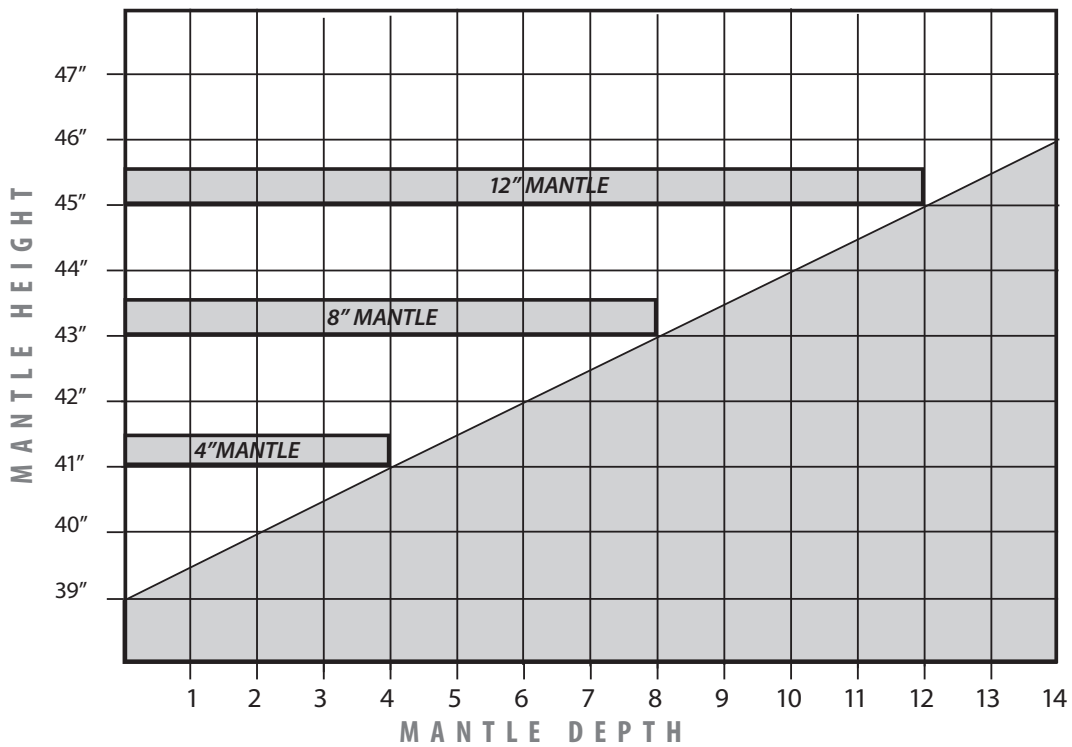

Figure 44: Minimum Mantel Height

Note: Minimum height of mantel if you intend on using a surround 31"

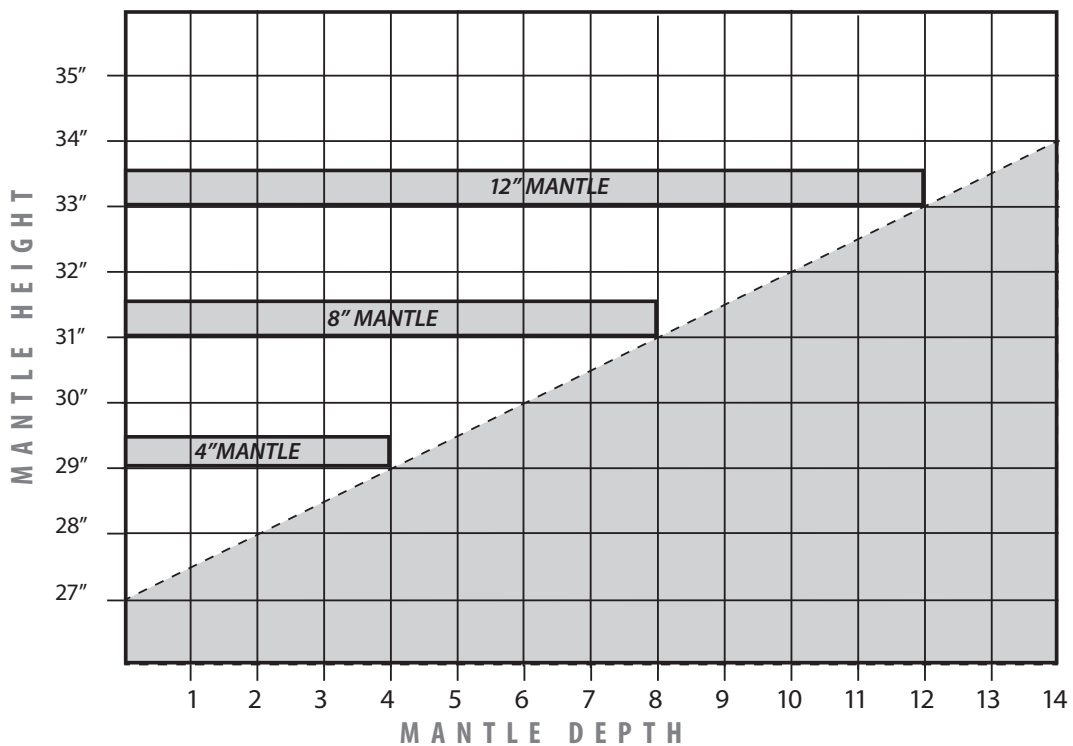

Figure 45: Minimum Mantel Height -- CSS Activated

INITIAL INSTALLATION

QUALIFIED INSTALLERS ONLY

If adding a mantel to the C34I please note the critical dimensions shown in Figure 46. These are minimum dimensions as per certification and must be followed.

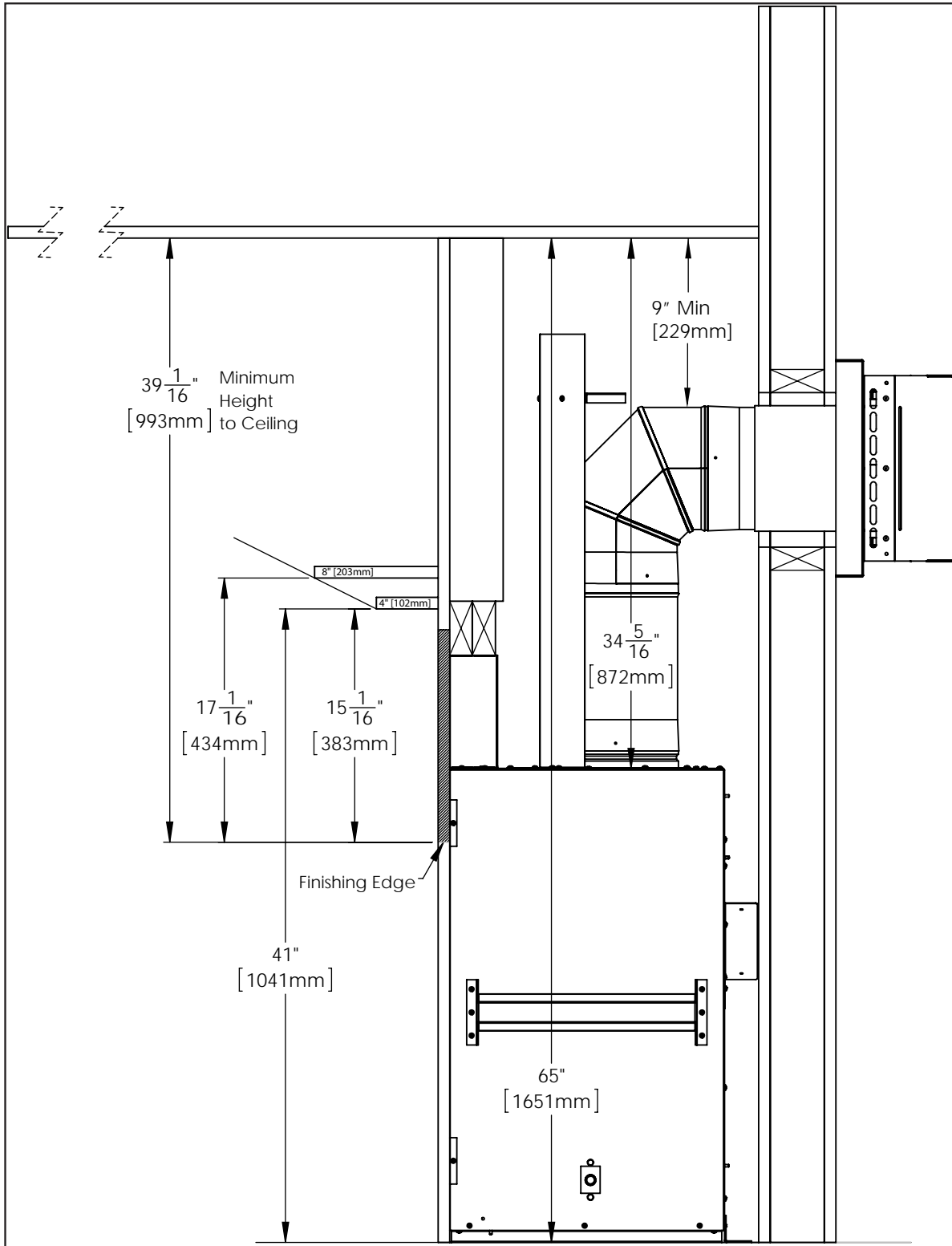

Figure 46: Install Dimensions with Mantel

INITIAL INSTALLATION

QUALIFIED INSTALLERS ONLY

INSTALLATION WITH RECESS

Refer to dimensions in Figure 47 if building a recess above the fireplace. Note the dimensions from the finishing edge to the stud below the recess finishing material. The vertical finishing material at the back of the recess must be spaced $\frac{7}{8}$ " off the vent shield. Also note the dimension from the vent pipe to the internal ciling this must be maintained if the fireplace is raised.

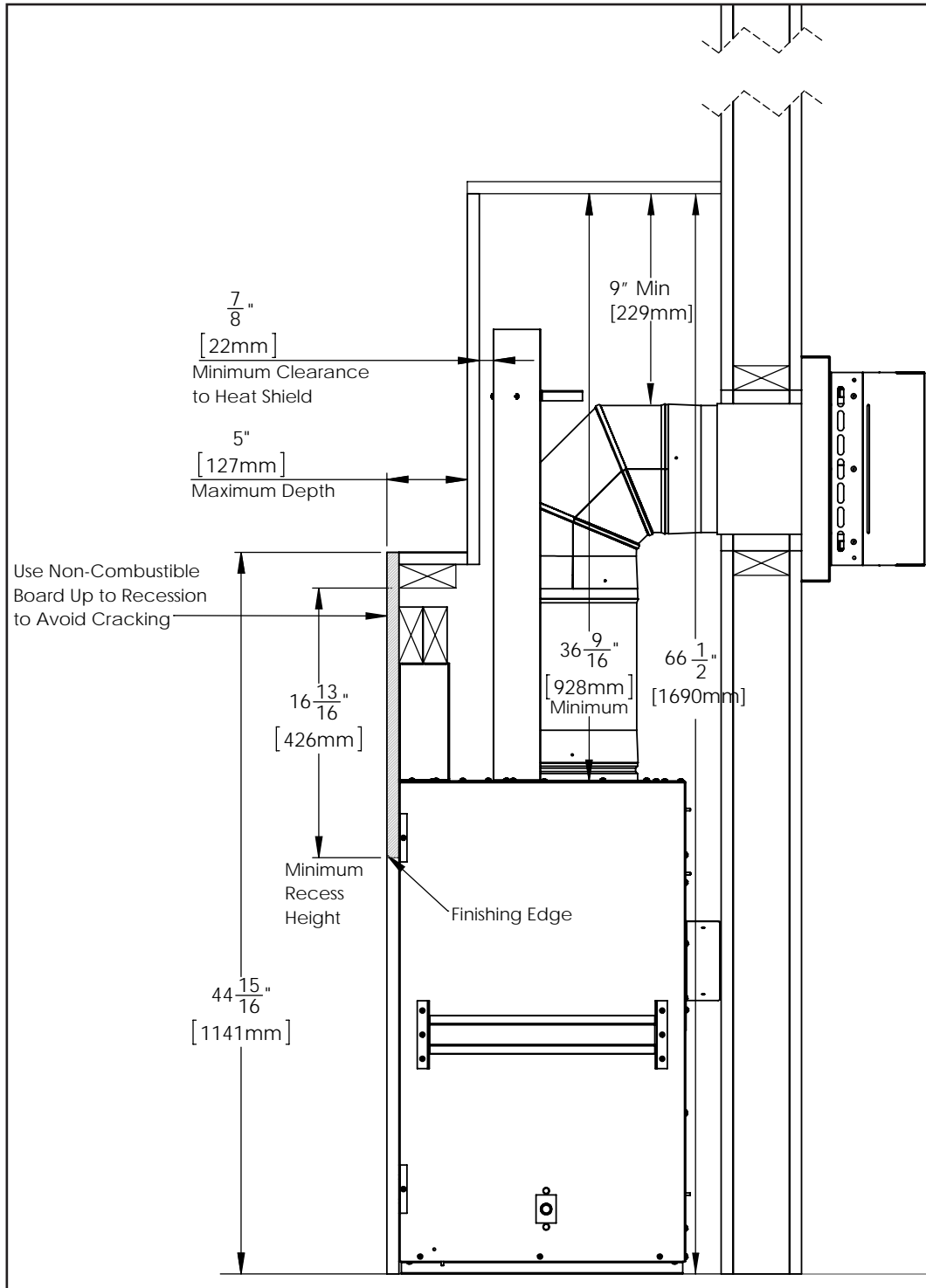

Figure 47: Install Dimensions with Recess

INITIAL INSTALLATION

CORNER INSTALLATION: QUALIFIED INSTALLERS ONLY

The dimensions for installing a fireplace in the corner of a room are given below. Refer to "INSTALLATION - ALLOWABLE CO-AXIAL VENT CONFIGURATIONS" for allowable pipe lengths.

Do not interfere with the structural integrity of the walls. Shown below are minimum clearances; increasing these dimensions is allowable as long as vent length remains in the allowable range.

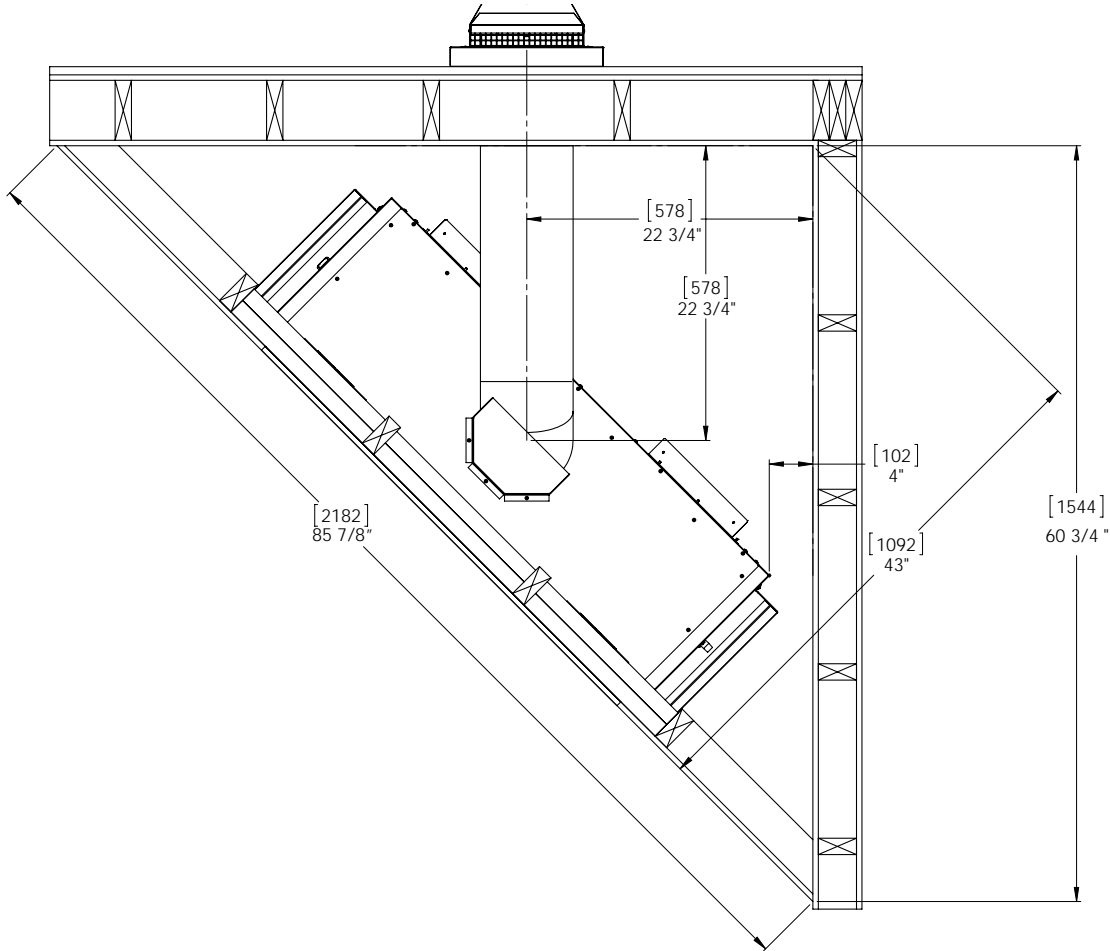

Figure 48: Dimensions for a Corner Installation

IMPORTANT: All installations must include the vertical vent shield. The horizontal vent shield is only installed if the fireplace is horizontally terminated with the minimum vertical rise of 12". If more than 12" of vertical rise is used in the vent configuration no horizontal shield is needed. See Figure 49 for shield install. Screws are pre-installed in cabinet and horizontal vent shield. Use a T-20 screwdriver or drill driver to remove screws then install shields.

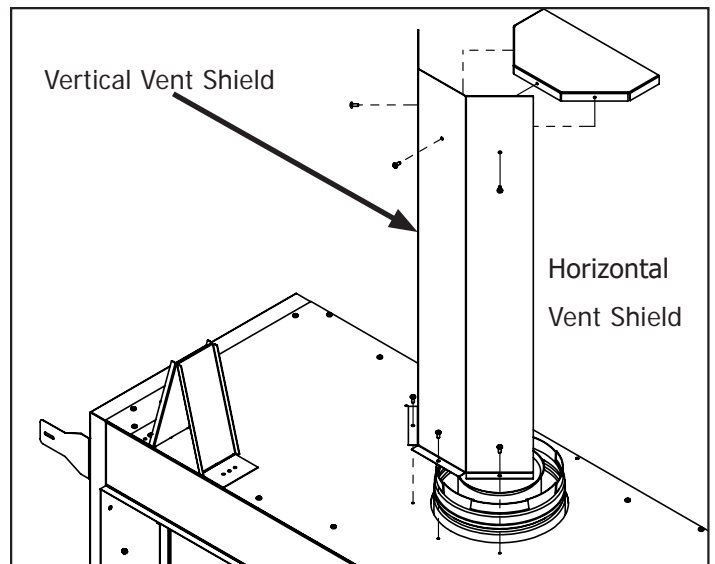

Figure 49: Vent Shielding Install

INITIAL INSTALLATION

QUALIFIED INSTALLERS ONLY

HORIZONTAL VENT INSTALL:

Figure 50 shows a horizontal vent installation with minimum clearances. The horizontal vent shield must be used when the minimum vent configuration is used. If more than 12" of vertical rise is used the shield should not be installed. The vent to ceiling clearance must be maintained no matter the additional vertical vent height; see page 32 & 33 for more details. A minimum of 1" clearance on all sides of the vent pipe must be maintained at all time unless specifically stated.

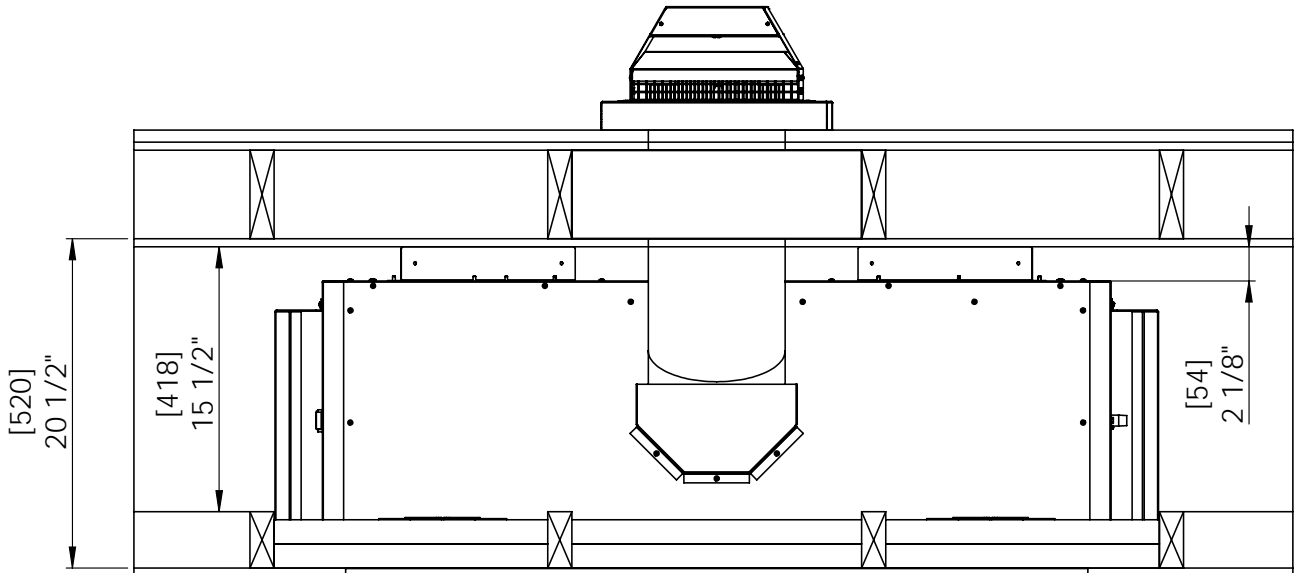

Figure 50: Dimensions for a Horizontal Installation

VERTICAL VENT INSTALL:

Figure 51 shows a vertical vent installation with minimum install clearances. Vertical vent shield is needed, the horizontal vent shield is not required for vertical vent configurations. A minimum of 1" clearance on all sides of the vertical vent pipe must be maintained at all time unless specifically stated. Please see Initial Installation - Vertical Termination for further details.

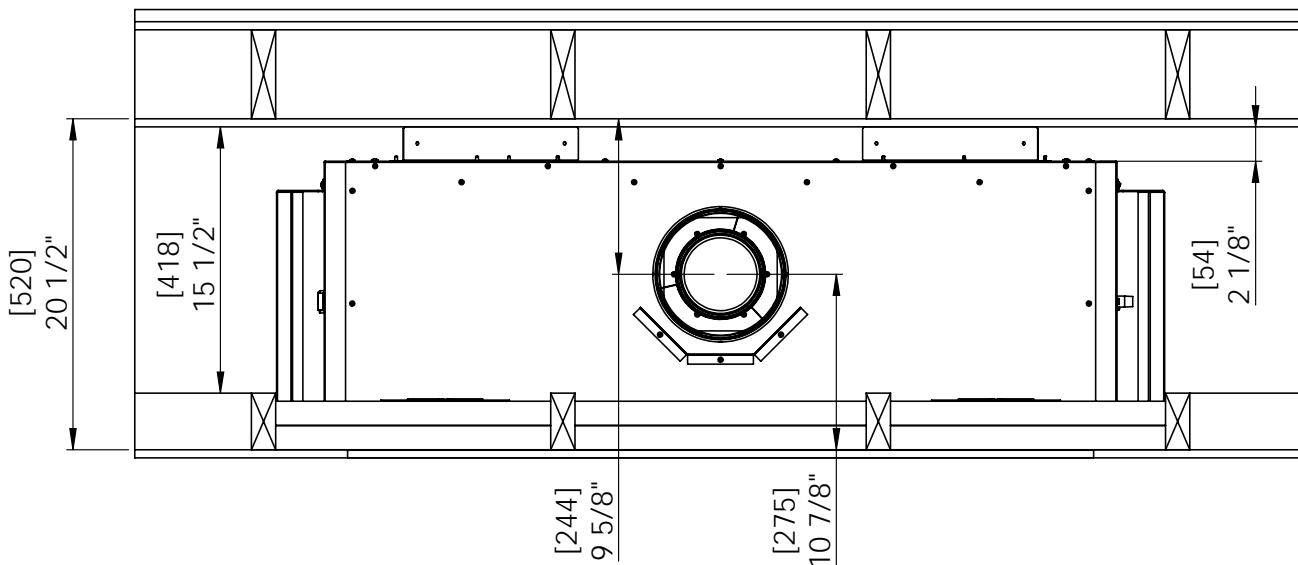

Figure 51: Dimensions for a Vertical Installation

INITIAL INSTALLATION

QUALIFIED INSTALLERS ONLY

TV INSTALLATION CONSIDERATIONS:

If you are planning to mount a TV above your fireplace some considerations must be made to ensure it is protected from the heat. A recess, mantel, or a combination of both will be needed in order to keep the heat away from the TV. To insure protection of electronics and art above the fireplace the Cool Surface System (CSS) should be activated or an optional Front or Side CSS kit should be installed. The CSS greatly reduces wall temperatures while still providing heat to the room.

During testing temperatures did not exceed 150°F (65°C) in a 5" deep recess. There is no guarantee that these temperatures will not harm the longevity of your TV. Make sure to consult your TV manufacturer's specifications to find the maximum allowable operating temperature. Since every home and installation is unique, temperatures should be verified at the time of install if possible. A TV should not be installed if temperatures exceed the manufacturer's maximum allowable temperature.

See Figures 52 & 53 for **minimum** TV installation clearances. Make sure there is 2" of clearance around the sides and top of the TV to allow for airflow. Remember these are **minimum** dimensions increasing them can only help reduce the temperature the TV is subjected to.

If installing with a mantel to protect the TV please see Figure 52 for clearances, it is highly recommended to use at least a 8" mantel. The **minimum** distance from the base of the unit to the bottom of the TV would be 45.75".

If a recessed installation is desired please see Figure 53 for TV clearances. The recess will need to protrude from the wall for proper protection, this dimension is dependant on the TV and TV mounting bracket depth. The **minimum** distance from the base of the unit to the bottom of the TV would be 47.00".

INITIAL INSTALLATION

QUALIFIED INSTALLERS ONLY

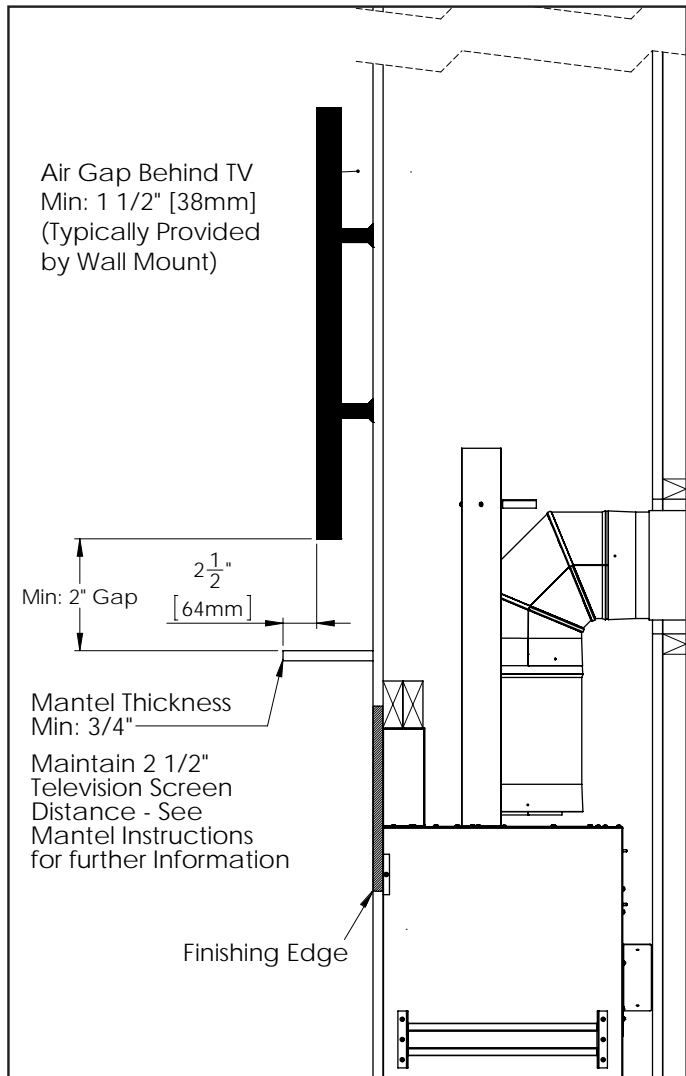

Figure 52: Minimum TV Install Clearances

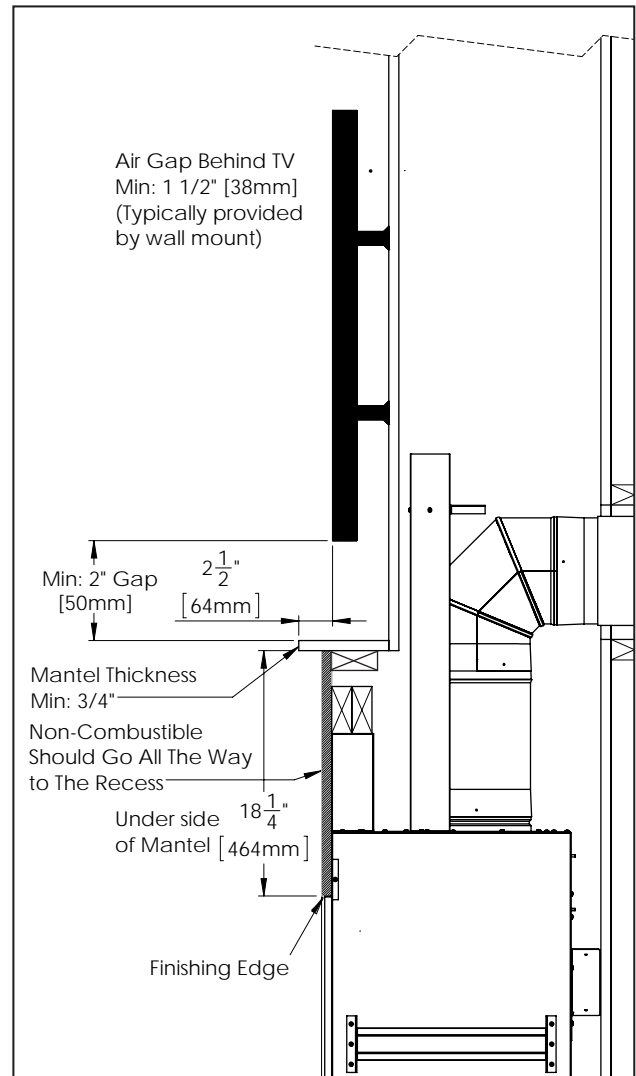

Figure 53: Recess Minimum TV Install Clearances

DIRECT VENT:

WARNING: This appliance has been designed to draw room air and discharge heated air from the openings around the finishing edge. Blocking or modifying these openings in any way can create hazardous situations. Only Approved Direct Vent may be used for installation of the C34I.

The minimum vent installation for the C34I must include a **12" vertical section and 90° elbow before being horizontally vented. Maximum Vertical venting is 40' (12.2 m)**. This model is vented with co-axial **5"** exhaust, **8"** intake aluminum or stainless steel approved rigid vent leading into a vertical or horizontal termination cap. The flue collar of this model will fit inside of a standard **5"x 8"** vent and must be either correctly interlocked or fastened, with three screws directly to the vent collar.

Check periodically that the vents are unrestricted. Also ensure that all direct vent pipes have been properly sealed and installed after routine inspection or cleaning. The air intake and exhaust pipes must be installed in the correct locations on the top of the C34I.

INITIAL INSTALLATION

QUALIFIED INSTALLERS ONLY

VENT TERMINATION RESTRICTIONS:

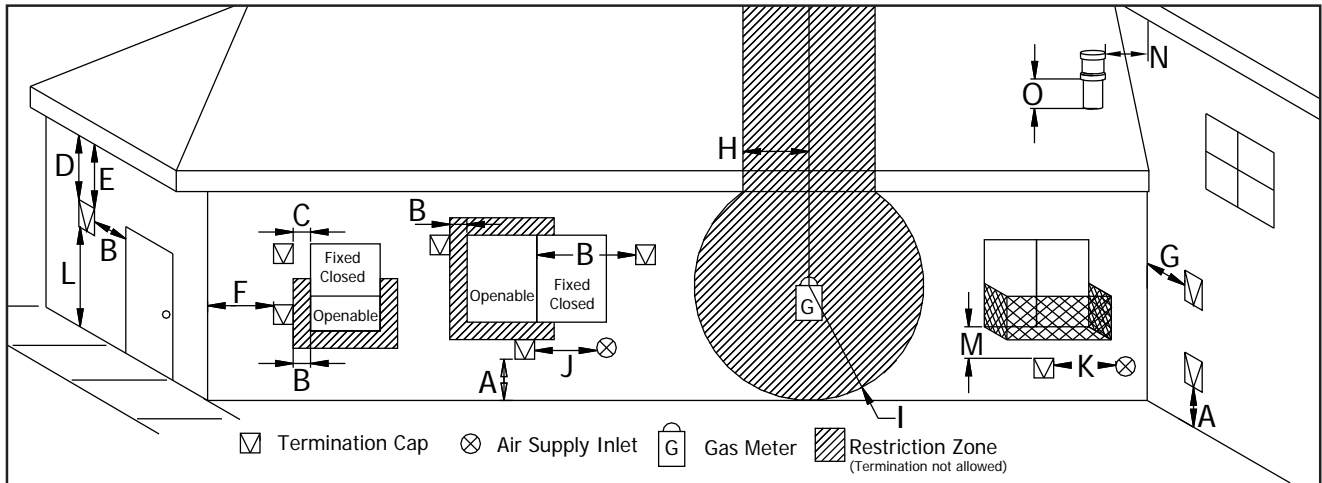

Figure 54: Vent Termination Restrictions, refer to Table 3

Table 3: Vent Termination Clearances

Letter	Canadian Installation ¹	US Installation ²	Description
A	12 in (30 cm)		Clearance above grade, verandah, porch, deck, or balcony.
B	12 in (30 cm)	9 in (23 cm)	Clearance from window or door that may be opened.
C	12 in (30 cm)*		Clearance from permanently closed window (to prevent condensation).
D	24 in (60 cm)*		Vertical clearance to ventilated soffit located above the terminal, within a horizontal distance of 2 ft (60 cm) from center line of terminal.
E	18 in (45 cm)*		Clearance to unventilated soffit.
F	12 in (30 cm)*		Clearance to outside corner.
G	12 in (30 cm)*		Clearance to inside corner.
H	3 ft (91 cm) within a height of 15 ft (4.5 m) above the meter/regulator assembly	3 ft (91 cm) within a height of 15 ft (4.5 m) above the meter/regulator assembly*	Clearance to each side of center line extended above meter/regulator assembly.
I	3 ft (91 cm)	3 ft (91 cm)*	Radial clearance around service regulator vent outlet.
J	12 in (30 cm)	9 in (23 cm)	Clearance to non-mechanical air supply inlet to building, or the combustion air inlet to any other appliance.
K	6 ft (1.83 m)	3 ft (91 cm) above if within 10 ft (3 m) horizontally	Clearance to mechanical air supply inlet.
L	7 ft (2.13 m) [†]	7 ft (2.13 m) ^{*†}	Clearance above paved sidewalk or paved driveway located on public property.
M	12 in / 30 cm ⁺	12 in / 30 cm ^{*+}	Clearance under verandah, porch, deck, or balcony.
N	12 in (30 cm)*		Clearance horizontally to any surface (such as an exterior wall) for vertical terminations.
O	12 in (30 cm)		Clearance above roof line for vertical terminations.

¹ In accordance with the current CSA B149.1, Natural Gas and Propane Installation Code.

² In accordance with the current ANSI Z223.1 NFPA 54, National Fuel Gas Code.

* These numbers are only estimates.

[†] A vent shall not terminate directly above a side walk or paved driveway that is located between two single family dwellings and it serves both dwellings.

⁺ Permitted only if verandah, porch, deck, or balcony is fully open on a minimum of two sides beneath the floor.

Clearances are in accordance with local installation codes and the requirements of the gas supplier.

INITIAL INSTALLATION

QUALIFIED INSTALLERS ONLY

VENTING CLEARANCES:

A **1" (25 mm)** clearance to combustibles must be maintained around any vertical vent pipe. Around a horizontal vent pipe, the clearance to combustibles should be **2" (51 mm)** above and **1" (25 mm)** on the sides and bottom. When combustible materials are directly above the first 90° elbow, **9" (229 mm)** of clearance is necessary.

Table 4: Vent Pipe Minimum Clearances

	Vertical Pipe to the Side Walls	Horizontal Pipe to the Sides & Bottom	Above First Elbow in Chase	Above Subsequent Elbows	Above Horizontal Vent Pipe	Wall Frame 8" (203mm) or less
Hard Pipe	1" (25mm)	1" (25 mm)	9" (229 mm)	3" (76 mm)	2" (51 mm)	Thimble Specific

See certified thimbles in venting section and frame accordingly. A thimble will assure the proper support and spacing requirements for the vent pipe as it passes through the exterior wall.

Installations in Canada require that a wall thimble be used for passing through walls and ceilings. All sealing and vapour barriers must comply with local building codes.

For installations using a horizontal thimble, a standard framed opening of 10 1/2" x 10 1/2" (39) is required. **For installations using a vertical thimble**, a standard 10 1/2" x 10 1/2" framed opening can be used.

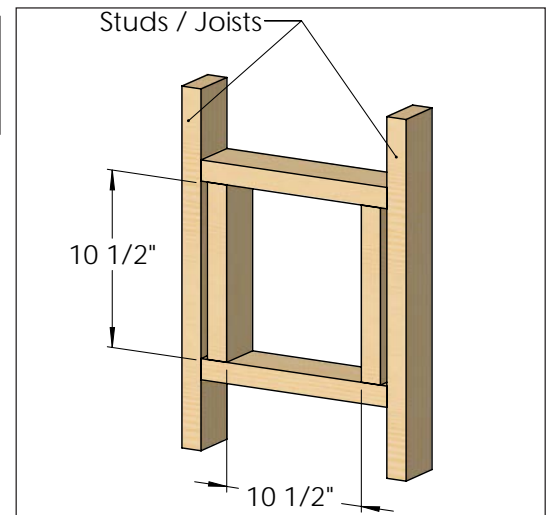

Figure 55: Vent Framing For Wall or Ceiling

INITIAL INSTALLATION

QUALIFIED INSTALLERS ONLY

FLEX VENTING:

This fireplace is certified to work with aluminium co-axial flex venting. Flex venting can be used in the same configurations as rigid pipe, see venting diagram for details. Flex venting is only to be used for the run, it must be adapted to rigid piping for exterior wall penetration and termination. **Note: Adhere to all rigid venting safety measures and clearances.**

Use 5X8 Flex Adapter Kit [50-3789]: This kit will allow you to adapt co-axial flex to the fireplace, make your vent run, then adapt back to rigid venting (**flex not included**).

Any 5X8 CSA or UL flue gas certified aluminum or stainless steel flex is acceptable. Proper spacers must be used to keep pipes from contacting each other. Proper venting spacers must be used, nothing makeshift. Examples of allowable flex pipe brands include, but are not limited to the following:

- M&G Duravent
- Selkirk Corp
- ICC
- Z-Flex
- Flexmaster
- Chim Flex
- Olympia
- BDM
- Metal-Fab

Only the flex venting and spacers are needed. You must use the flex adapter kit and a certified rigid pipe termination cap.

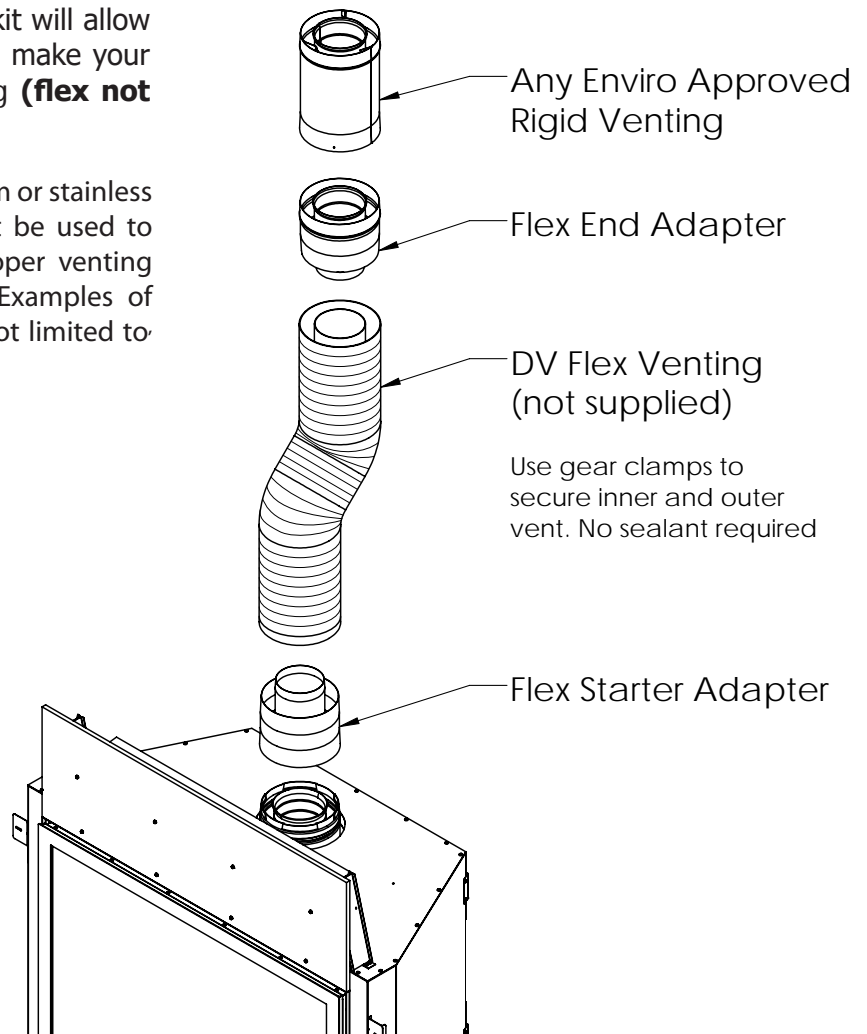

Figure 56: Flex Vent Adaptor Kit

INSTALLATION NOTES:

- Do not bend flex vent over 90 degrees.
- All horizontal runs should have a minimum 1/4" (6mm) rise per foot for optimal performance.
- Do not allow the inner flex pipe to contact the outer pipe, keep it pulled tight and use spacer springs.
- Spacers are required at the start, middle, and end of each elbow to ensure gap is maintained.
- Do not add any extensions to the preset kits, if more length is required, use rigid pipe.
- No need for liquid sealant; secure flex venting with aluminum vent tape and apply sufficient self-tapping screws.

INITIAL INSTALLATION

QUALIFIED INSTALLERS ONLY

APPROVED VENTING PARTS:

This fireplace has been tested and certified for use with the venting brand names listed in Table 5. Refer to Table 6 below for part numbers of commonly used parts for both venting systems. For more venting parts please visit the respective manufacturers' website.

WARNING: Do not mix parts from different vent manufacturers' systems.

Table 5: Approved Vent Manufacturers

Manufacturer	Brand Name	Nominal Sizes
ICC	EXCELDirect	5" x 8"
Duravent	Direct Vent Pro	5" x 8"
Selkirk	DIRECT-TEMP	5" x 8"
Selkirk	AMP DV	5" x 8"
Metal-Fab Inc.	Sure-Seal	5" x 8"

EXCEPTION TO WARNING: This product has been evaluated by Intertek for using a DirectVent Pro starting collar in conjunction with venting brand names listed in Table 5. Use of these systems with the DirectVent Pro starting collar is deemed acceptable and does not affect the Intertek listing of the appliance.

Table 6: Approved Vent Parts

Duravent Direct Vent Pro	ICC EXCELDirect	Selkirk DIRECT-TEMP	Amerivent AMV DV	Metal-Fab Sure-Seal DV	Description
58DVA-06	5DL6	5DT-06		5D6	6" pipe length
			5D7		7" pipe length
58DVA-09	5DL9	5DT-09			9" pipe length
58DVA-12	5DL1	5DT-12	5D12	5D12	12" pipe length
58DVA-18		5DT-18		5D18	18" pipe length
58DVA-24	5DL2	5DT-24	5D2	5D24	24" pipe length
58DVA-36	5DL3	5DT-36	5D3	5D36	36" pipe length
58DVA-48	5DL4	5DT-48	5D4	5D48	48" pipe length
58DVA-60					60" pipe length
58DVA-E30	5DE30				30° elbow
58DVA-E45	5DE45	5DT-EL45	5D45L	5D45L	45° elbow
58DVA-E90	5DE90	5DT-EL90	5D90L	5D90A, 5D90L	90° elbow
58DVA-VSS, DVA-BVS	VSS	5DT-VS/VSK	5DHVS, DVSK	5DVS	Vinyl siding standoff/sheild
58DVA-WT3, 58DVA-WTU3	5WT	5DT-WT	5DWT	5DWT, 5DWT11	Wall thimble
58DVA-SC	5QSC, SC	5DT-SC	5DSC	5DSC	Storm collar
58DVA-WFS		5DT-FS		5DFSH	Wall Fire stop
58DVA-FS	5CS	5DT-FS	5DFSP	5DFS, 5DSPFS	Ceiling Fire stop
58DVA-IS	5AS	5DT-AIS	5DAIS12, AIS36	5DIS	Attic Insulation Shield
58DVA-WS	5WS	5DT-WS/B	5DWS	5DWS	Wall strap/support/band
58DVA-VCH	5SVT	5DT-VT	5DVC	5DVT	High wind vertical termination
58DVA-HC	5HT	5DT-HC	5DHCS	5DHT	High wind horizontal termination*
46DVA-WG	HTS		4DHWS	8DVTS	Wind / Heat Shield
				5DAL	3" to 10" pipe, adjustable
58DVA-17TA					11" to 17" pipe, adjustable
58DVA-24TA					17" to 24" pipe, adjustable
	5DLA30				16.5" to 29" pipe, adjustable
	5DLS1				1 7/8" to 9" slip length pipe
	5DLS2				1 7/8" to 21" slip length pipe
58DVA-F6	6EFA	5DT-AF6	5DF	5DF	Flashing, 0/12 to 6/12 roof pitch
58DVA-F12	6EFB	5DT-AF12	5DF12	5DF-12	Flashing, 7/12 to 12/12 roof pitch
58DVA-FF	6EF			5DFT	Flat Roof Flashings
58DVA-CFK	4MF				Masonry Flashing

*Duravent Sconce Termination not permitted for use

INITIAL INSTALLATION

QUALIFIED INSTALLERS ONLY

ALLOWABLE CO-AXIAL VENT CONFIGURATIONS:

Figure 57 shows the range of venting options using either vertical or horizontal terminations; any layout that remains within the shaded area is acceptable. Having the fewest number of elbows is ideal as they tend to restrict air movement. The total length of horizontal vent pipe can not exceed 20 feet (6.1m) and the total

vent length can not exceed 40ft (12.2m). Any combination of rise and run can be used as long as it lays within the shaded area (a total of three (3) 90° elbows or six (6) 45° elbows can be used). In addition to what is shown, if a 90° elbow is used in the horizontal plane, 3 feet (91.4cm) must be subtracted from the allowable horizontal run (for each 45° elbow, 1½ feet (45.7cm) must be subtracted).

Note: The unit will come with 6 restrictor rings. One of these rings may be needed depending on the vent configuration. This must be installed in order to achieve proper efficiency and flame appearance.

Flame Appearance: Pin point on the graph where your vent configuration will lay. Remember to consider elbows in the HORIZONTAL plane account for horizontal distance as stated above. Use the corresponding exhaust restrictor according to the graph. See the following section in this manual for installation details. Your climate and altitude may alter what restrictor is required for your particular application.

If your flame is low, flickery, and more blue then increase the restrictor one size. If your flame is tall, thin, and lazy then decrease the restrictor one size. Use your judgement after the unit has been running for about 20 minutes.

Caution: Wait until the unit has completely cooled before changing the restrictor.

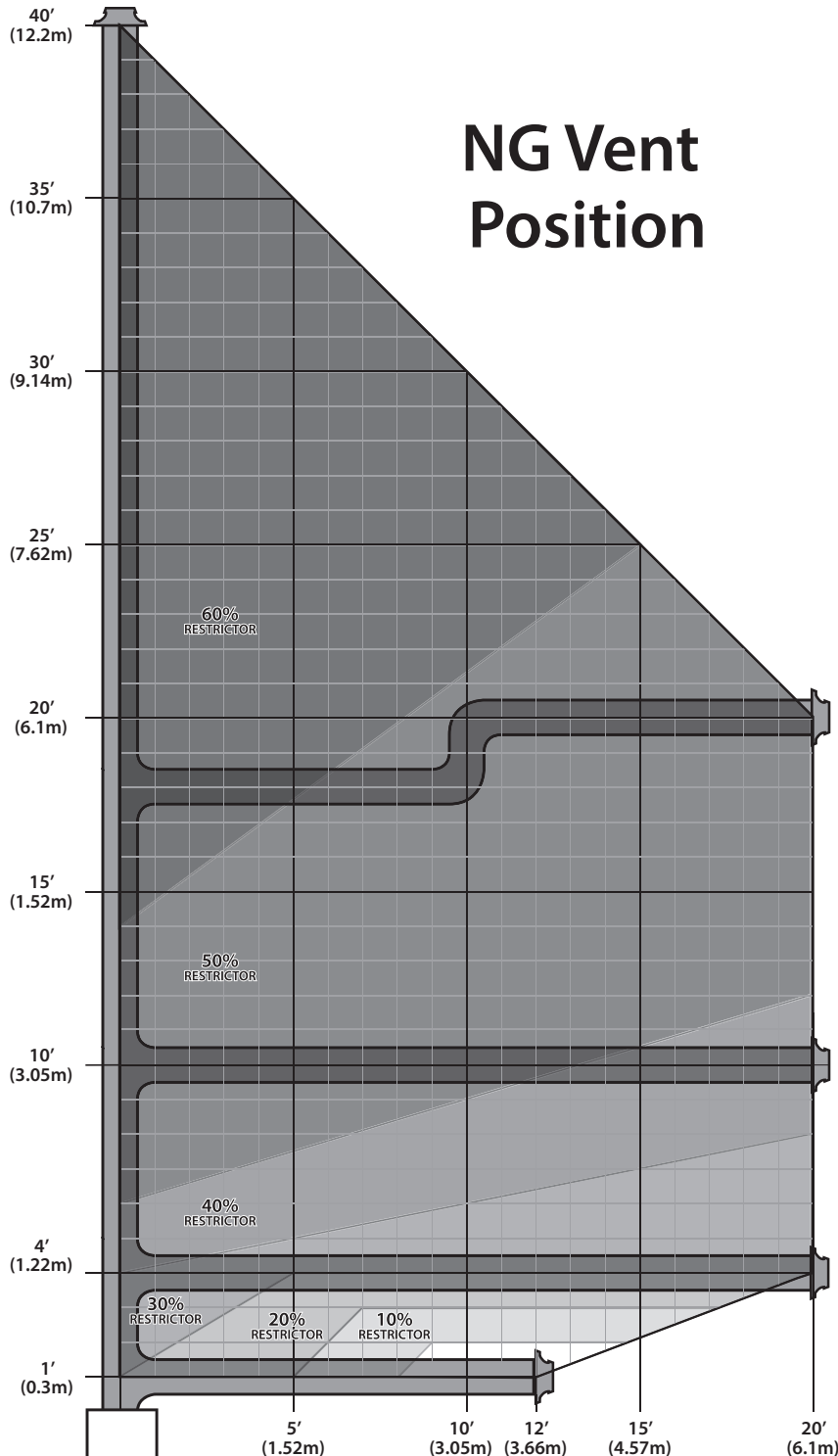

Figure 57: Natural Gas Vent Graph

INITIAL INSTALLATION

QUALIFIED INSTALLERS ONLY

LP Vent Position

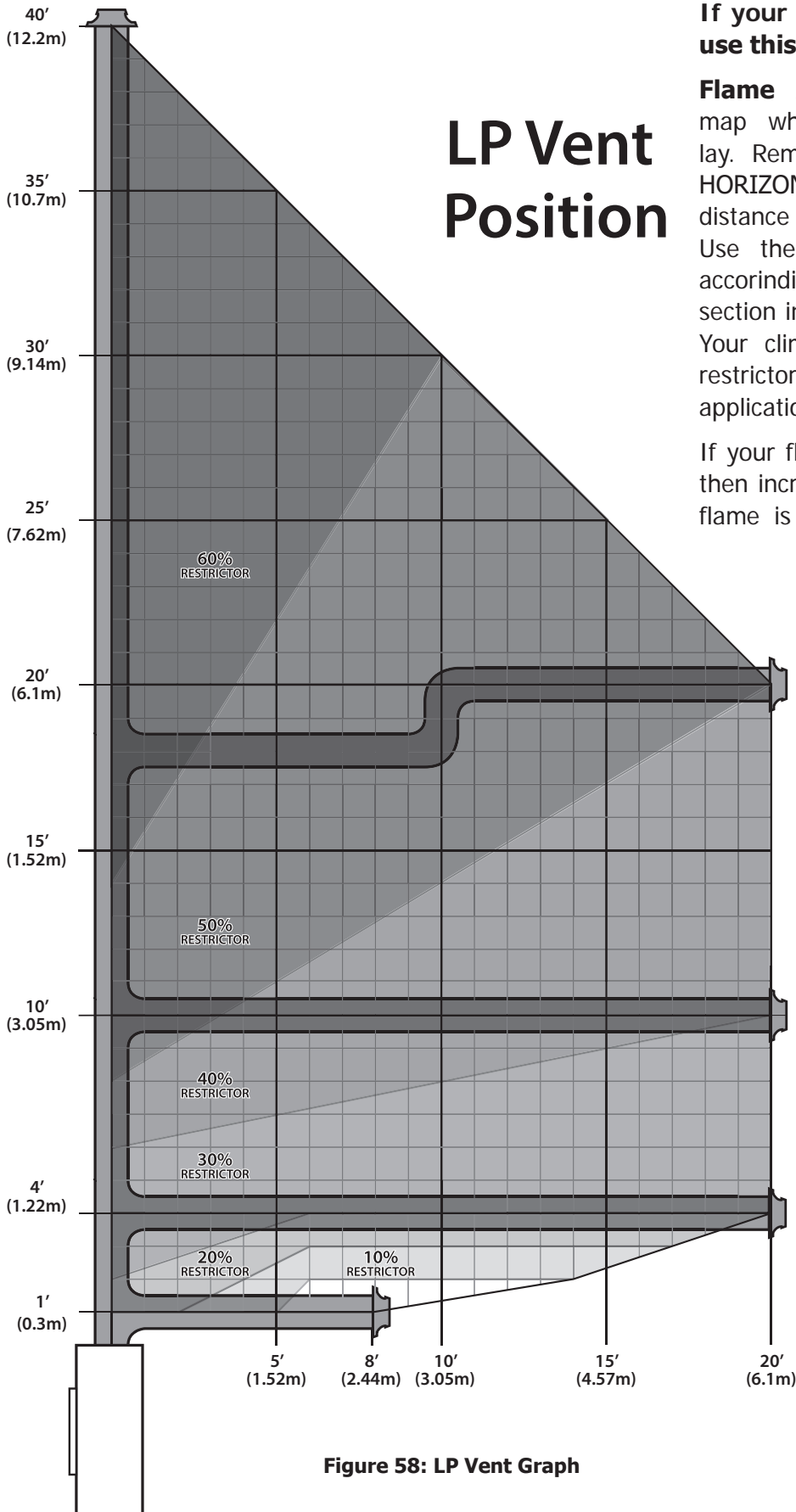

Figure 58: LP Vent Graph

If your C34I has been converted to LP use this venting diagram.

Flame Appearance: Pin point on the map where your vent configuration will lay. Remember to consider elbows in the HORIZONTAL plane account for horizontal distance as stated on the previous page. Use the corresponding exhaust restrictor according to the graph. See the following section in this manual for installation details. Your climate and altitude may alter what restrictor is required for your particular application.

If your flame is low, flickery, and more blue then increase the restrictor one size. If your flame is tall, thin, and lazy then decrease the restrictor one size. Use your judgement after the unit has been running for about 20 minutes. If your having difficulty achieving a healthy flame with LP then try opening the air shutter completely.

Caution: Wait until the unit has completely cooled before changing the restrictor.

INITIAL INSTALLATION

QUALIFIED INSTALLERS ONLY

EXHAUST RESTRICTOR SETTING:

When installing the C34I it may be necessary to add a restrictor in the firebox to control the combustion and flame appearance. The exhaust restrictor ring kit is included in the manual bag, to install the exhaust restrictor the safety screen assembly and glass door must be removed, see the Maintenance and Service section see page 10. There are six different restrictor sizes, make sure you install the correct size. Refer to the vent graphs on the previous pages for possible vent configurations and the corresponding restrictor setting. Proper restriction is crucial to efficient fireplace operation and best possible looking flame.

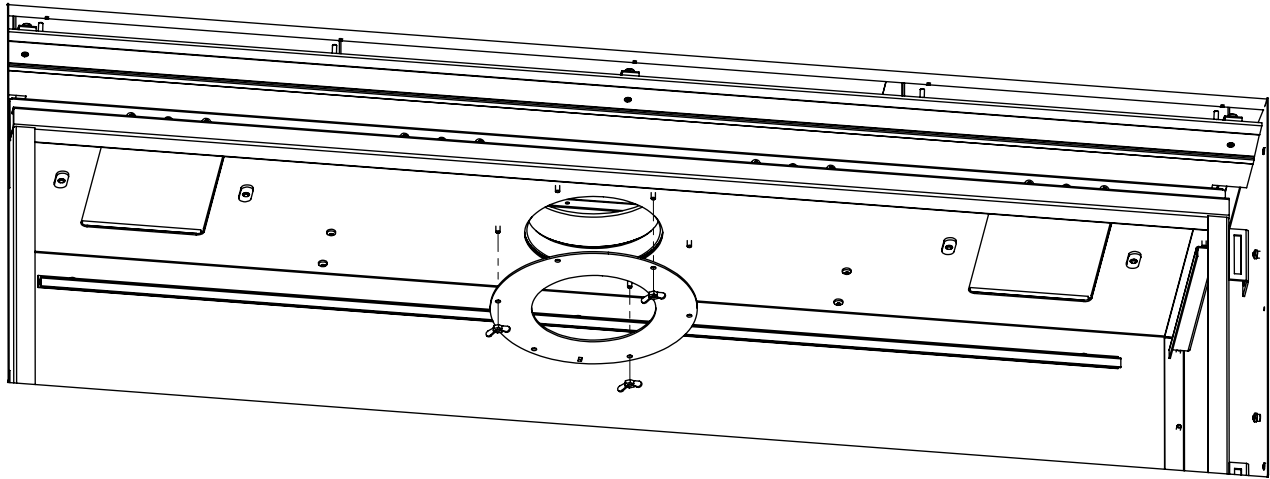

Figure 59: Restrictor Install

Note: There are six different restrictor sizes, they are marked with rectangular holes which coincide with the percentage of restriction (Figure 60).

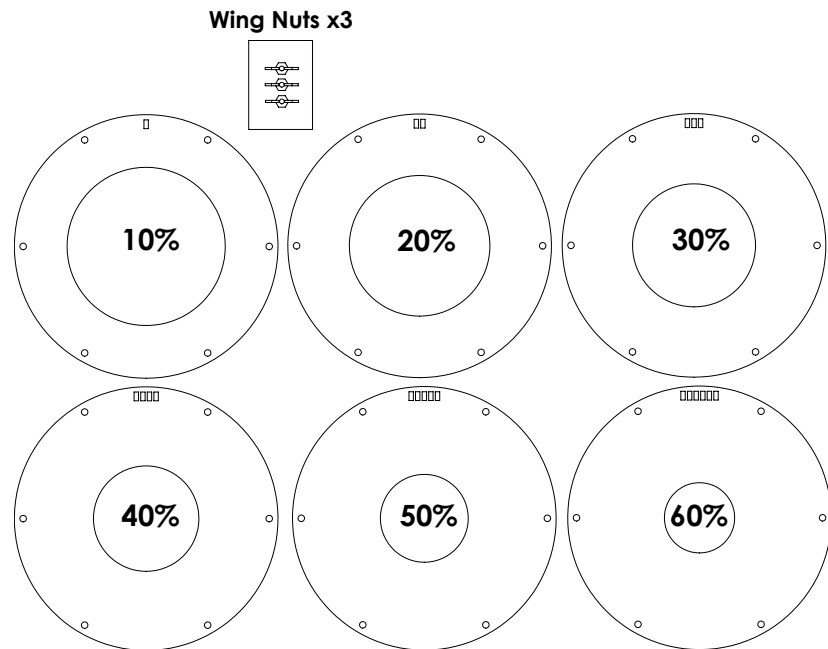

Figure 60: Restrictor Ring Kit

INITIAL INSTALLATION

QUALIFIED INSTALLERS ONLY

HORIZONTAL TERMINATION:

1. A MINIMUM OF 12" [305mm] VERTICAL RISE PLUS AN ELBOW IS REQUIRED WHEN HORIZONTALLY TERMINATING WITH AN APPROVED VENT CAP.

2. Horizontal pipes must not be level. For every 12" (305 mm) of horizontal travel (away from the stove), there should be at least 1/4" (6.4 mm) of vertical rise. Never allow the vent to run downward, as this could cause high temperatures or even present the possibility of a fire.

3. The exterior of the horizontal vent termination must not be blocked or obstructed.

4. If the vent termination is not being attached to wood, the four wood screws provided should be replaced with material appropriate fasteners.

5. For buildings with vinyl siding, a vinyl standoff should be installed between the vent cap and the exterior wall. Attach the vinyl standoff to the horizontal termination. Note that the termination bolts onto the flat portion of the standoff, providing an air space between the wall and the vent termination. The air gap prevents excessive heat from possibly melting the vinyl siding.

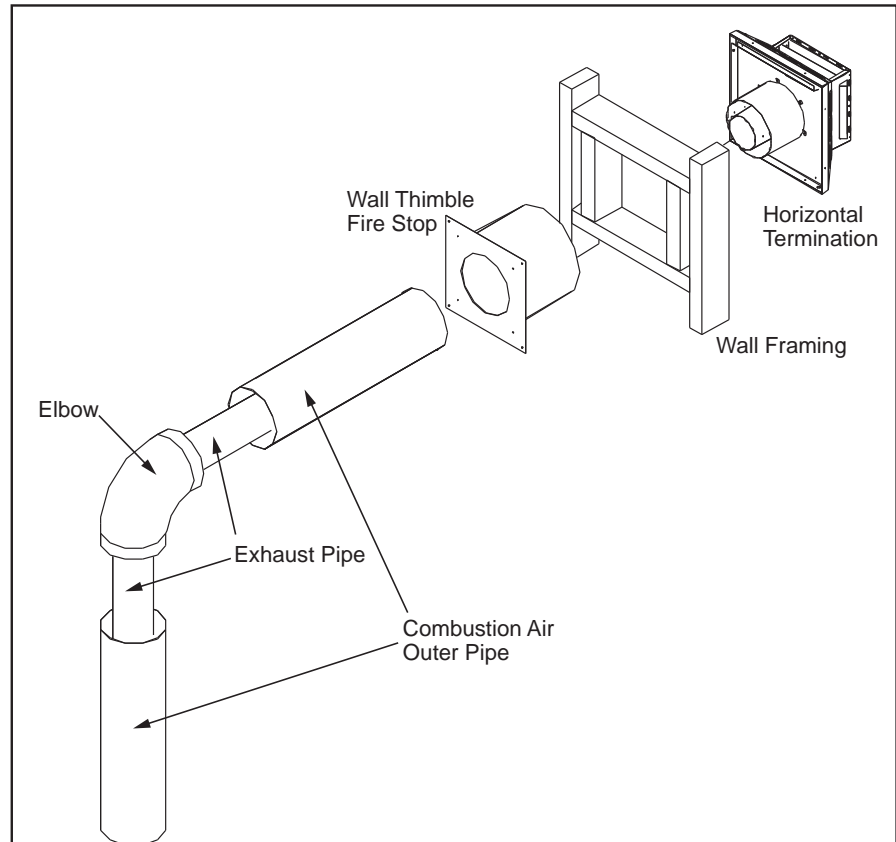

Figure 61: Horizontal Vent Termination

6. Horizontal pipes must be supported every 3' (914 mm). Plumber's all round strap will suffice.

7. When running horizontal pipe, clearances to combustibles must be maintained **1 inch (25 mm)** sides, **1 inch (25 mm)** bottom, and **2" (51 mm)** top.

Step 1. Set the fireplace in the desired location. Check to determine if wall studs will be in the way when the venting system is attached. If this is the case, the location of the fireplace may have to be adjusted or the venting may have to be offset.

Step 2. Direct vent pipe sections are designed with special twist-lock connections. Dry fit the desired combination of pipe and elbows to the appliance adaptor.

Step 3. With the pipe in the correct position and attached to the fireplace, mark the wall for a hole as directed by specified wall thimble dimensions. Cut and frame the hole in the exterior wall where the vent will be terminated. If the wall being penetrated is made of a non-combustible material (i.e. masonry or concrete) a **8 1/2" (21.6 cm)** hole is acceptable.

INITIAL INSTALLATION

QUALIFIED INSTALLERS ONLY

- Step 4.** With the hole now framed, the wall thimble installed, and the pipe extending into the wall, proceed to the outside. Attach the termination to the pipe using RTV and Mil-Pac or Rutland No 78 Stove and Gasket Cement to seal joints. The vent pipe must extend into the vent cap at least **1¼ inches (3.2 cm)**. Secure the connection between the vent cap and the pipe by attaching the two (2) sheet metal straps, which extend from the vent cap assembly to the outer wall of the vent pipe. Bend any remaining portion of the strap back towards the vent cap. Security Secure Vent uses a twist lock cap.
- Step 5.** Position the horizontal vent termination in the center of the **10" (25.4 cm)** square hole and attach to the exterior wall with the four screws provided. The arrow on the vent termination should be pointing up. Run a bead of non-hardening mastic around the edges of the vent cap, to make a seal with the wall. Ensure the proper clearances to combustibles have been maintained.

VERTICAL TERMINATION:

- Step 1.** Check the instructions for required clearances (air spaces) to combustibles when passing through ceilings, walls, roofs, enclosures, attic rafters, or other nearby combustible surfaces. Do not pack air spaces with insulation.
- Step 2.** Set the gas appliance in the desired location. Drop a plumb bob down from the ceiling to the position of the appliance flue exit, and mark the location where the vent will penetrate the ceiling. Drill a small hole at this point. Next, drop a plumb bob from the roof to the hole previously drilled in the ceiling, mark the spot where the vent will penetrate the roof. Determine if ceiling joists, roof rafters, or other framing will obstruct the venting system. You may wish to relocate the appliance, or to offset, to avoid cutting load bearing members.
- Step 3.** To install the Round Support Box/Wall Thimble in a flat ceiling, cut a **10" (25.4 cm)** square hole in the ceiling, centered in the hole drilled in Step 2. Frame the hole as shown on page 39.
- Step 4.** Assemble the desired lengths of black pipe and elbows necessary to reach from the appliance adapter up through the Round Support Box. Insure that all pipe and elbow connections are in their fully twist-locked position.

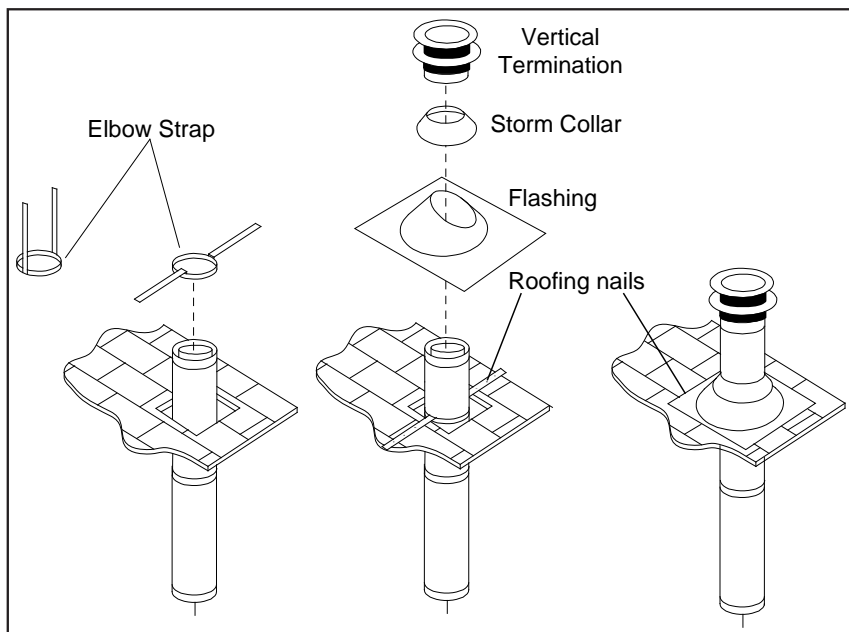

Figure 62: Vertical Vent Termination

INITIAL INSTALLATION

QUALIFIED INSTALLERS ONLY

- Step 5.** Cut hole in the roof centered on the small hole placed in the roof from Step 2. The hole should be of sufficient size to meet minimum requirements for Clearance to Combustibles, as specified. Continue to assemble lengths of pipe and elbows necessary to reach from the ceiling support box up through the roof line. Galvanized pipe and elbows may be utilized in the attic, as well as above the roof line. The galvanized finish is desirable above the roof line, due to the higher corrosion resistance.
- Step 6.** Once the pipe sections have been joined, and run up through the hole in the roof, slip an elbow strap over the exposed sections, bend the support straps outwards, and push the elbow strap down to the roof level, as shown in Figure 62. Tighten the clamp around the pipe section. Use a level to make sure the pipe is truly vertical. With roofing nails, secure the support straps to the roof. Seal the nails holes heads with non-hardening mastic. Trim the excess length of the support straps that extend out beyond the edge of the flashing.
- Step 7.** Slip the flashing over the pipe section protruding through the roof. Secure the base of the flashing to the roof with roofing nails. Use a non-hardening sealant between the uphill edge of the flashing and the roof. Insure the roofing material overlaps the top edge of the flashing. Verify that you have at least the minimum clearance to combustibles at the roof line.
- Step 8.** Continue to add pipe sections until the height of the vent cap meets the minimum code requirements. Refer to Figure 63 and Table 7. Note that for steep roof pitches, the vent height must be increased. In high wind conditions, nearby trees, adjoining roof lines, steep pitched roofs, and other similar factors can result in poor draft, or down drafting. In these cases, increasing the vent height may solve the problem.
- Step 9.** Slip the storm collar over the pipe, and push it down to the top of the roof flashing as shown in Figure 62. Use the non-hardening sealant around the joint between the pipe and the storm collar.
- Step 10.** Twist-lock the vent cap.

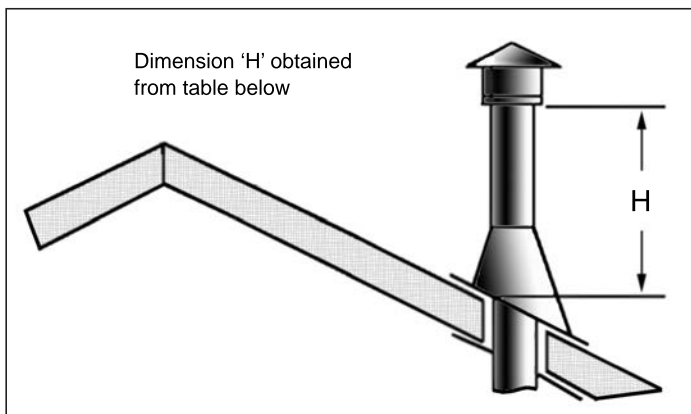

Figure 63: Height of Vertical Termination;
Reference Table 7

Table 7: Minimum 'H' for Figure 63.

Roof Pitch	Minimum Height (H)	
	Feet	Meters
Flat to 7/12	1	0.3
Over 7/12 to 8/12	1.5	0.46
Over 8/12 to 9/12	2	0.61
Over 9/12 to 10/12	2.5	0.76
Over 10/12 to 11/12	3.25	0.99
Over 11/12 to 12/12	4	1.22
Over 12/12 to 14/12	5	1.52
Over 14/12 to 16/12	6	1.83
Over 16/12 to 18/12	7	2.13
Over 18/12 to 20/12	7.5	2.29
Over 20/12 to 21/12	8	2.44

INITIAL INSTALLATION

QUALIFIED INSTALLERS ONLY

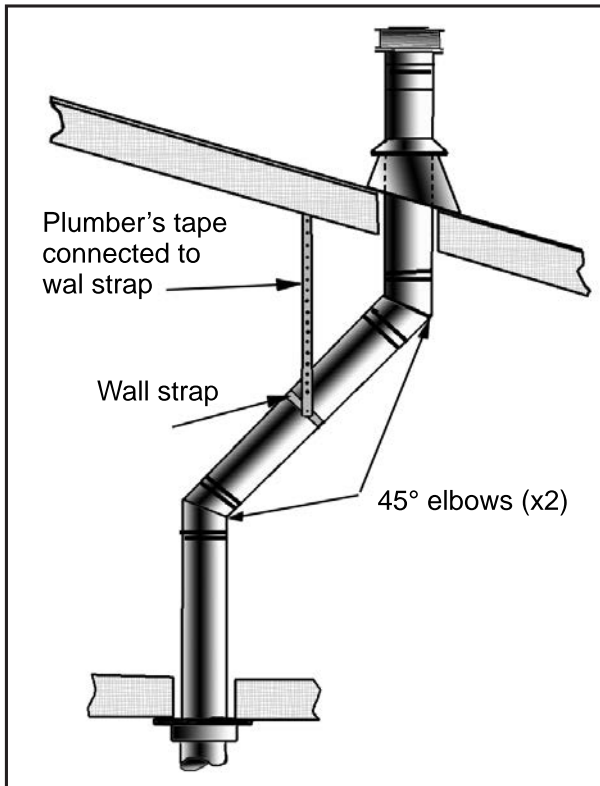

Figure 64: Use of Wall Straps.

NOTES:

- (1) If an offset is necessary in the attic to avoid obstructions, it is important to support the vent pipe every **3' (914 mm)**, to avoid excessive stress on the elbows, and possible separation. Wall straps are available for this purpose (see Figure 64).
- (2) When ever possible, use 45° degree elbows instead of 90° degree elbows. The 45° degree elbow offers less restriction to the flow of flue gases and intake air.
- (3) For multi story installations; a ceiling firestop is required at the second floor, and any subsequent floors. The opening should be framed to **10" (254 mm) x 10" (254 mm)** inside dimensions, in the same manner as shown in Figure 65.

- (4) Any occupied areas above the first floor, including closets and storage spaces, which the vertical vent passes through, must be enclosed. The enclosure may be framed and sheet-rocked with standard building materials. However consult the appliance manufactures installation instructions for the minimum allowable clearance between the outside of the vent pipe, and the combustible surfaces of the enclosure. Do not fill any required air spaces with insulation.

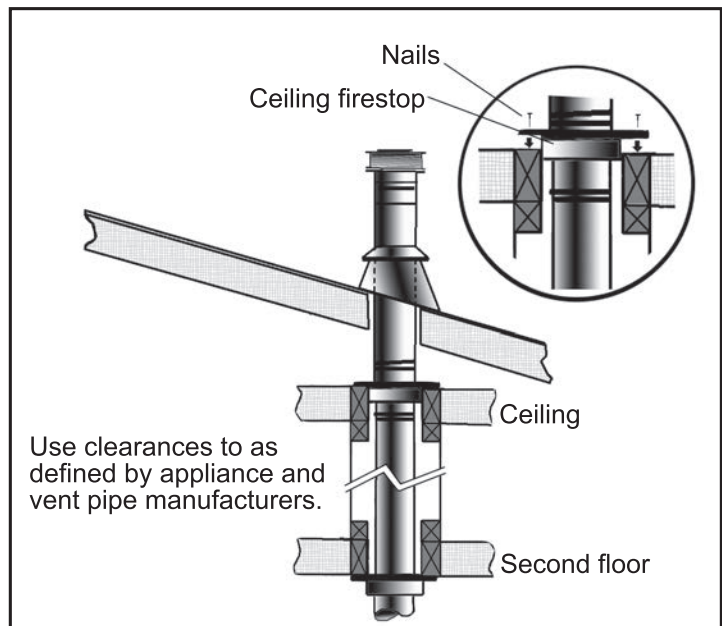

Figure 65: Multi-Story Vent Pipe Installation

INITIAL INSTALLATION

QUALIFIED INSTALLERS ONLY

GAS LINE CONNECTION AND TESTING:

WARNING: Only persons licensed to work with gas piping may make the necessary gas connections to this appliance.

GAS LINE CONNECTION

- This stove is equipped with a certified flexible pipe located on the right side of the unit terminating in a 3/8" Male NPT fitting. Consult your local authorities codes or the CAN/CGA B 149 (1 or 2) installation code in Canada, or in the USA gas installations follow either local codes or the current edition of the National Fuel Gas Code ANSI Z223.1.
- The efficiency rating of this appliance is a product thermal efficiency rating determined under continuous operating conditions and was determined independently of any installed system.

The appliance and its shutoff valves must be disconnected from the gas supply piping system during any pressure testing where the pressure exceeds 1/2 PSIG (3.45 KPa) or damage will occur to the valve.

The appliance must be isolated from the gas supply piping system by closing its individual manual shutoff valve during any pressure testing of the gas supply piping system at test pressures equal to or less than 1/2 psig (3.45 KPa).

Always check for gas leaks with a soap and water solution after completing the required pressure test.

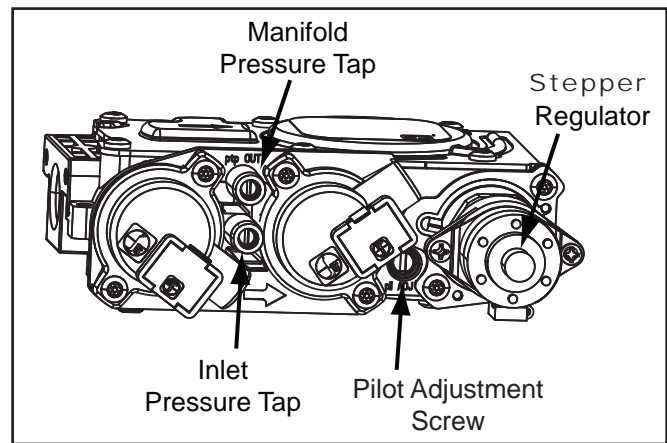

Figure 66: Fully Labeled Gas Valve.

TO TEST VALVE PRESSURES

The pressure taps are located on the top right of the valve shown in Figure 66.

- Turn set screw 1 turn counter clockwise to loosen,
- Place 5/16" (8 mm) I.D. hose over pressure tap system.
- Check pressures using a manometer.
- When finished, release pressure, remove hose & tighten set screw.

Table 8: Pressure and BTU Information.

	Natural Gas	Propane
Main Orifice	#37	#52
Manifold Pressure	3.6" W.C. (0.89 KPa)	10.0" W.C. (2.49 KPa)
Min. Manifold Pressure	1.6" W.C. (0.39 KPa)	6.4" W.C. (1.59 KPa)
Max Supply Pressure	7.0" W.C. (1.74 KPa)	11.0" W.C. (2.74KPa)
Min. Supply Pressure	4.5" W.C. (1.12 KPa)	10.4" W.C. (2.59 KPa)
Max BTU/hr Input	30,000 BTU/hr (8.79 kWh)	30,000 BTU/hr (8.79 kWh)
Min. BTU/hr Input	19,500 BTU/hr (5.71 kWh)	23,000 BTU/hr (6.74 kWh)

NEVER USE AN OPEN FLAME FOR LEAK TESTING.

INITIAL INSTALLATION

QUALIFIED INSTALLERS ONLY

ELECTRICAL REQUIREMENTS:

The fireplace must be electrically connected and grounded in accordance with local codes or, in the absence of local codes, with the current CSA C22.1 Canadian Electrical Code Part 1, Safety Standards For Electrical Installations, or The National Electrical Code ANSI / NFPA 70 in the US.

WARNING: The electrical grounding instructions must be followed. The fan kit is equipped with a three-prong (grounding) plug for your protection against shock hazard, and should be plugged directly into a properly grounded three-prong outlet. DO NOT cut or remove the grounding prong from this plug.

CAUTION: When servicing controls, label all wires prior to disconnection. Wiring errors can cause improper and dangerous operation. Verify proper operation after servicing.

If any of the original wire as supplied with the appliance must be replaced, it must be replaced with 18 AWG wire with a temperature rating of 105°C

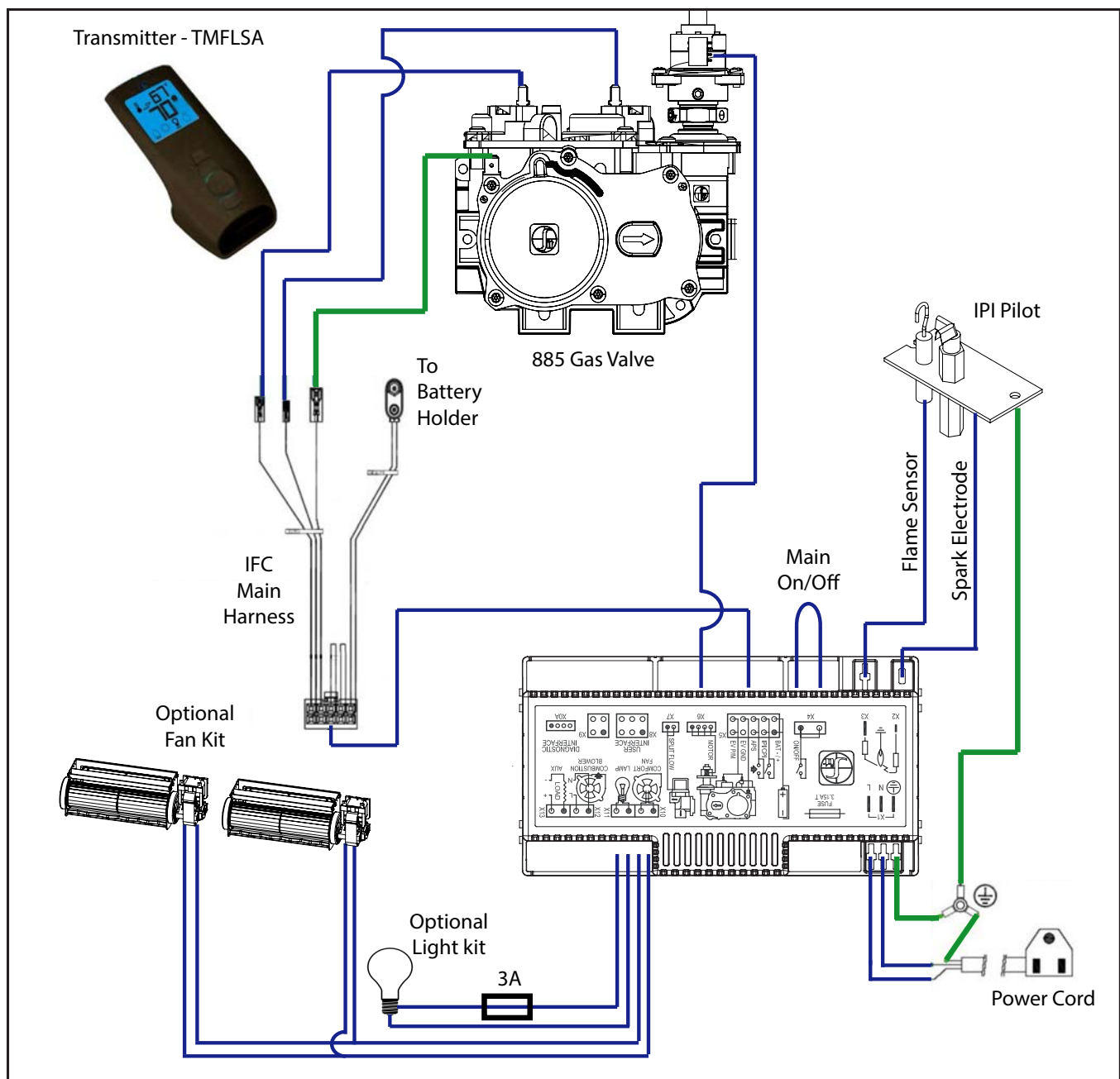

Figure 67: C34I Wiring Diagram

INITIAL INSTALLATION

QUALIFIED INSTALLERS ONLY

The C34I needs a hard wired power connection in order for the unit to operate. There is also a battery pack that takes four AA batteries in case there is a loss of power.

All electrical connections must be made by a certified electrician.

There is an electrical box located in the cabinet on the left side of the fireplace. The Power wire connection is to be made inside the electrical box. There is a strain relief on the outside of the cabinet to secure the wiring in place. The receptacle should be wired as shown in figure 68. If wiring in the convection fan kit or light kit options please see wiring diagrams.

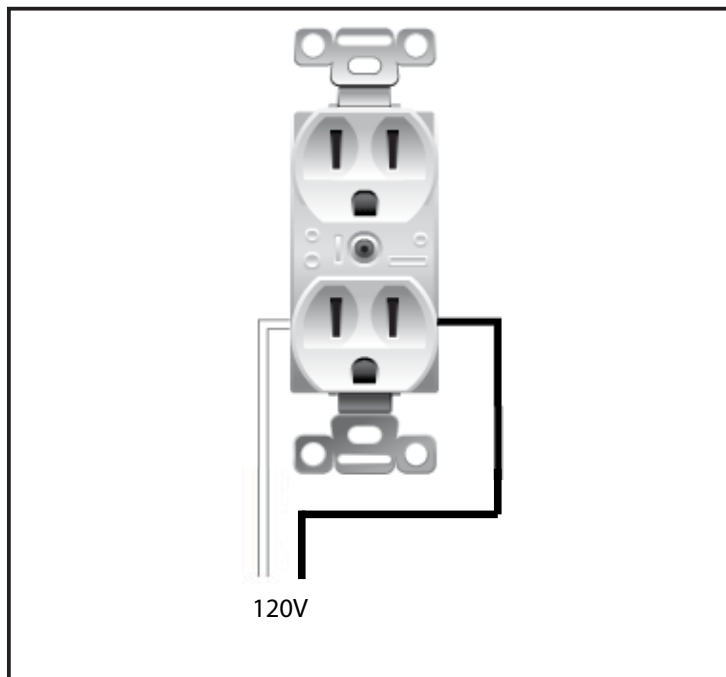

Figure 68: C34I Receptacle Wiring

IPI Dual Convection Fan Kit (50-3760)

The C34I has an optional dual convection fan kit that can be installed at before or after the fireplace installation. The fans are operated by the remote controller. The fans can be turned on or off at anytime with the remote. There are also 6 different fan speed settings.

The fireplace must be electrically connected and grounded in accordance with local codes or, in the absence of local codes, with the current CSA C22.1 Canadian Electrical Code Part 1, Safety Standards For Electrical Installations, or The National Electrical Code ANSI / NFPA 70 in the US..

CAUTION: When servicing controls, label all wires prior to disconnection. Wiring errors can cause improper and dangerous operation. Verify proper operation after servicing. If any of the original wire supplied with the appliance must be replaced, it must be replaced with 18 AWG wire with a temperature rating of 105°C.

INITIAL INSTALLATION

QUALIFIED INSTALLERS ONLY

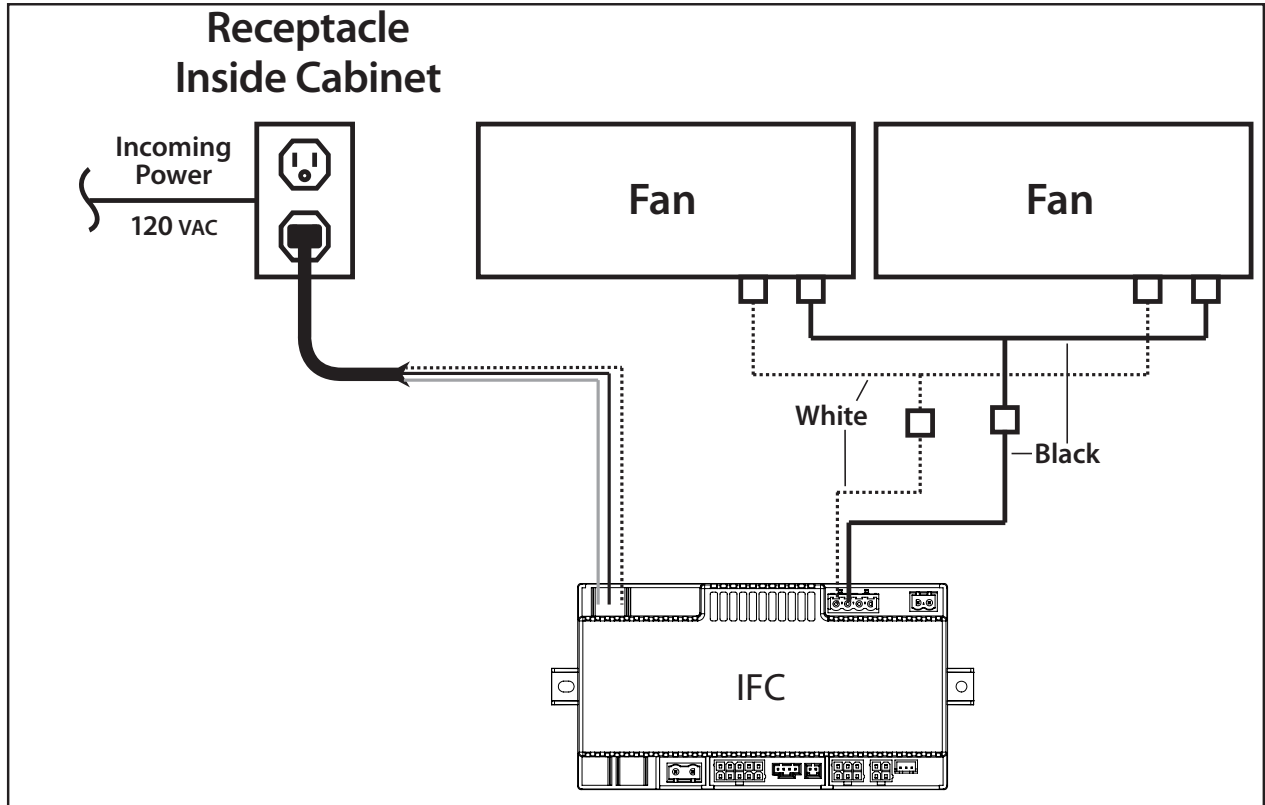

Figure 69: Fan Kit Wiring Diagram

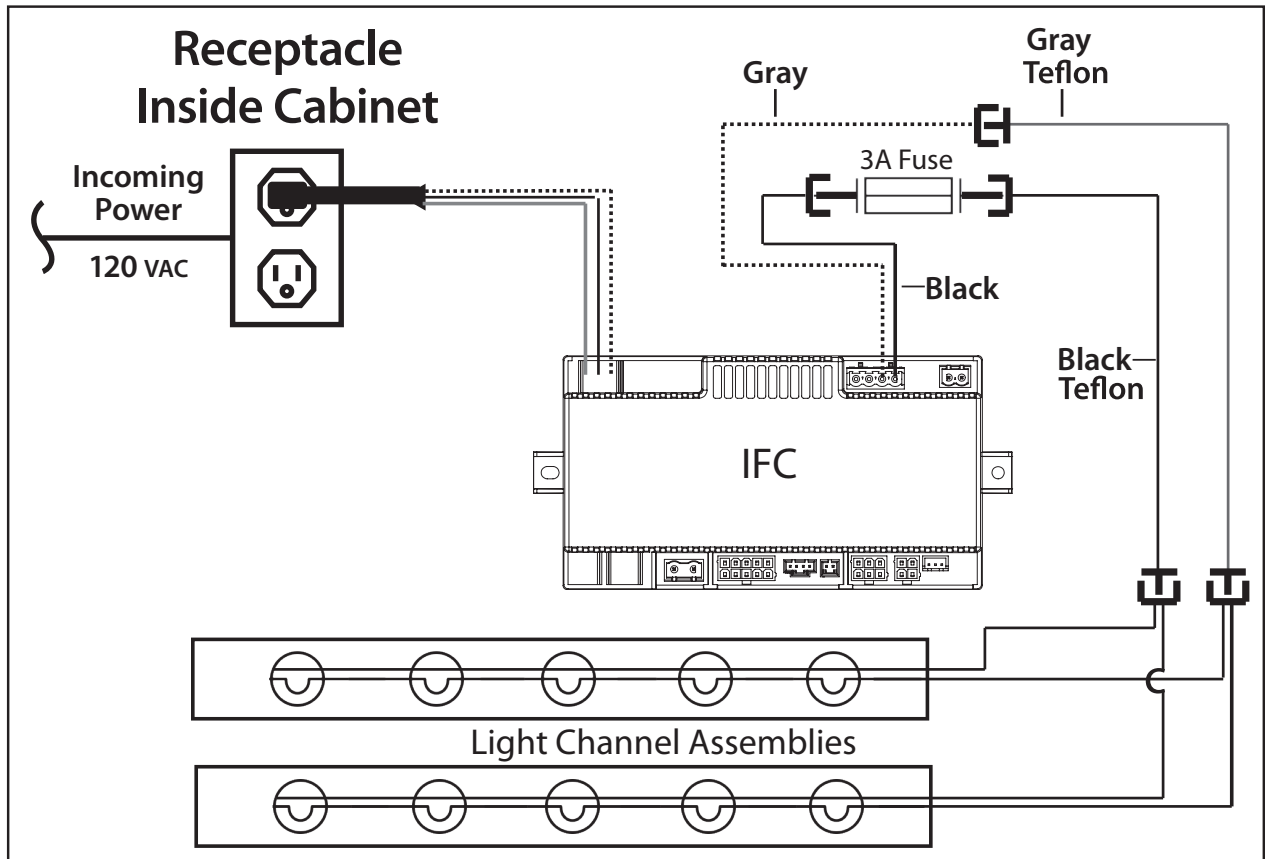

Figure 70: Light Kit Wiring Diagram

SECONDARY INSTALLATION

C34I Light Kit (50-3331)

The C34I has an optional light kit that is wired into the IFC.

The fireplace must be electrically connected and grounded in accordance with local codes or, in the absence of local codes, with the current CSA C22.1 Canadian Electrical Code Part 1, Safety Standards For Electrical Installations, or The National Electrical Code ANSI / NFPA 70 in the US..

CAUTION: When servicing controls, label all wires prior to disconnection. Wiring errors can cause improper and dangerous operation. Verify proper operation after servicing. If any of the original wire supplied with the appliance must be replaced, it must be replaced with 18 AWG wire with a temperature rating of 105°C. If the original wire supplied to the light bulbs is damaged you must contact your dealer. This is special high rated oven wire and it must be replaced with the same.

BURNER TRAY INSTALLATION:

There are two styles of burner tray . The standard burner tray is supplied with the unit and used for all media base options with the exception; the Light Kit includes a perforated burner tray to allow light to come through. Both tray styles are handled the same and removed with 6 screws using a T-20 screwdriver.

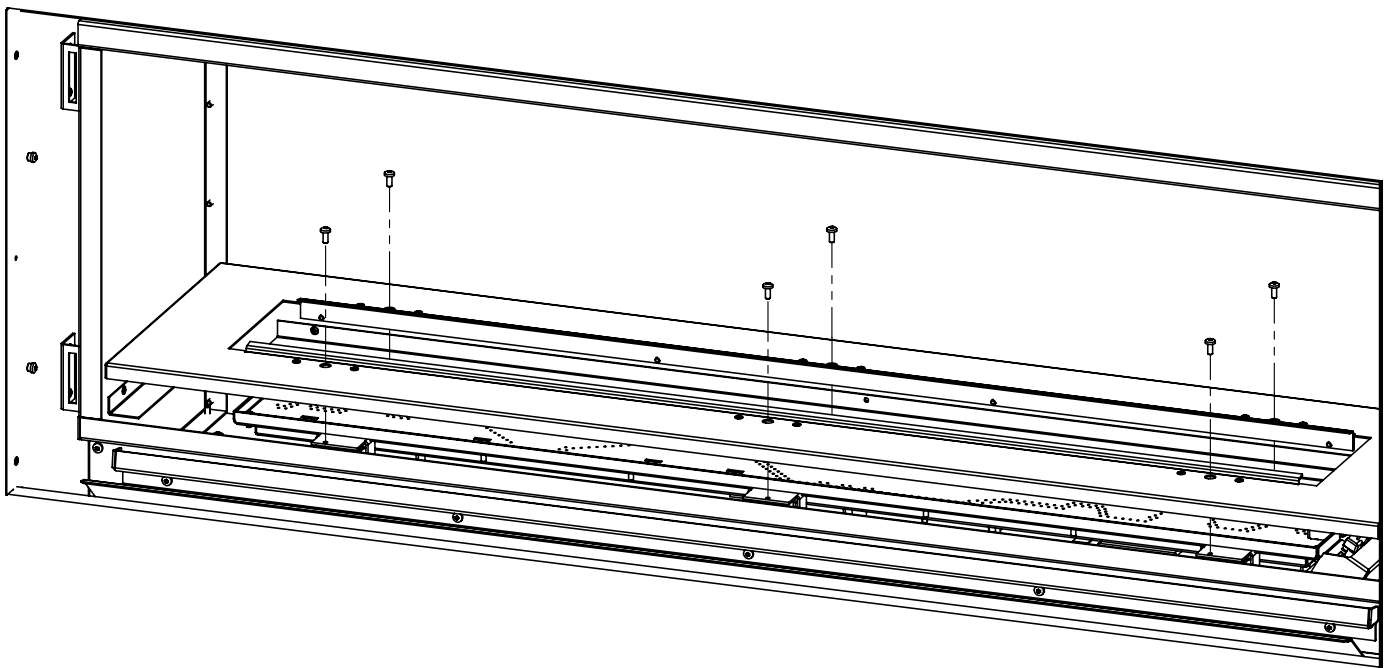

Figure 71: Standard Burner Tray Install/Removal

SECONDARY INSTALLATION

PANEL AND MEDIA INSTALLATION:

1. Remove the safety screen and glass door
2. If you are installing 50-3331 (Light Kit) Remove the burner tray now using a T-20 Torx screwdriver; refer to SECONDARY INSTALLATION - LIGHT KIT INSTALLATION or see instruction sheet included with the kit. Install perforated burner tray once lights are installed.
3. Place your burner media into the burner pan (vermiculite or glass media). Create a thin layer that evenly covers the entire burner pan; pat it down gently. **If flame looks uneven with overly high or low sections the media can be adjusted. If flame is too high make media thicker, if low thin media out.**

WARNING: Be sure there is no media in the protected pilot area of the burner pan.

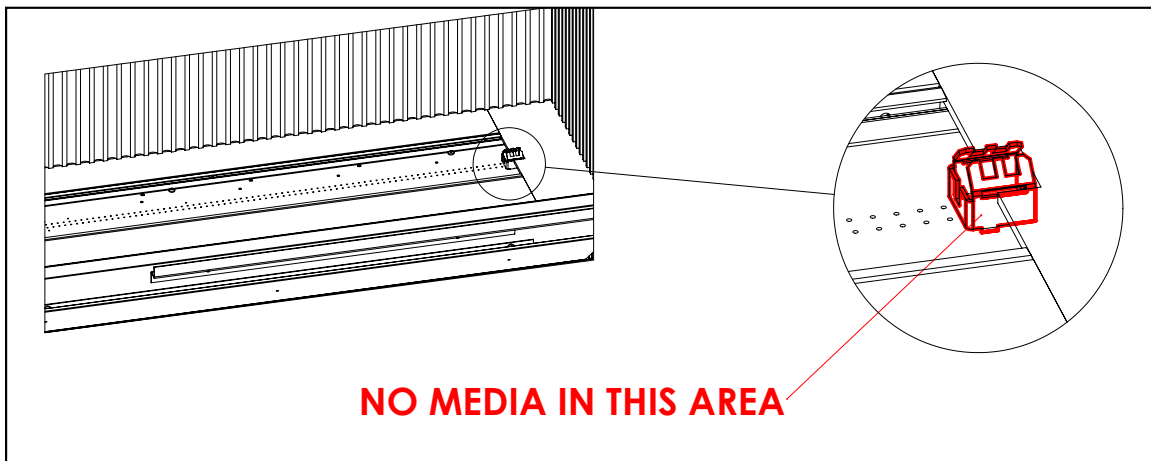

Figure 72: Protected Pilot Area

4. Wear clean vinyl gloves when handling 50-3326 (Fluted) and 50-3328 (Ledgestone) to prevent skin contact with the refractory. Wear clean vinyl gloves when handling 50-3329 (Enameled) to prevent smudging; use denatured alcohol to clean. Unwrap your new Enviro liner set from their protective packaging. Be careful not to scratch or bump then liners as they are fairly fragile. If the liners arrive damaged please contact your nearest Enviro dealer.
5. Remove the 3 liner retainers from inside the firebox using a T-20 Torx screwdriver.

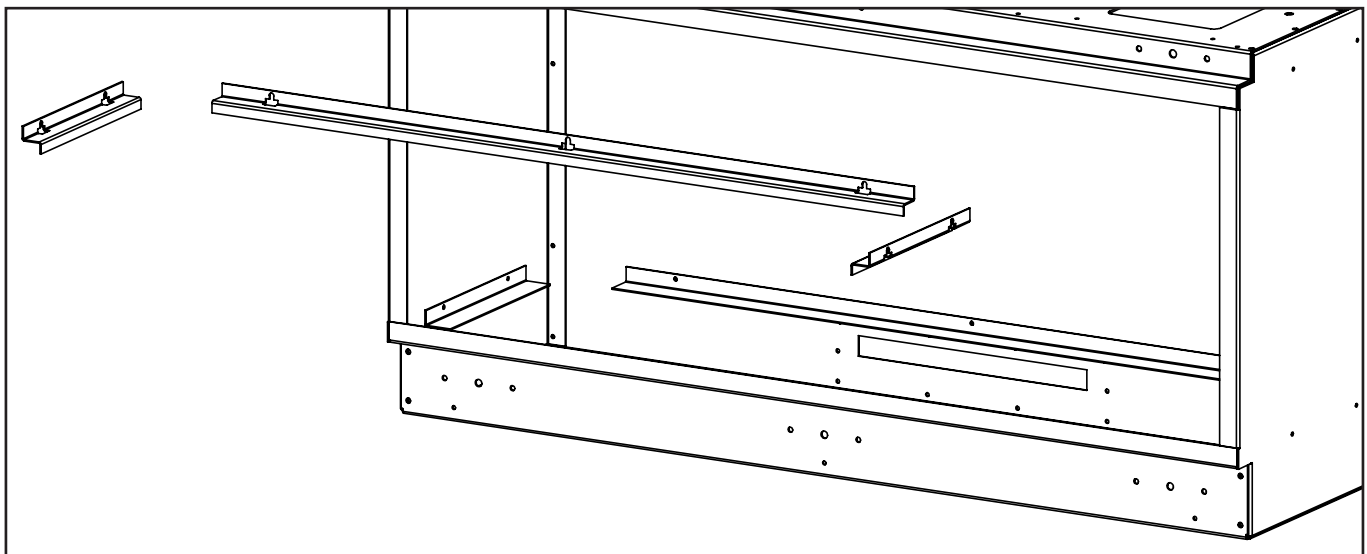

Figure 73: Panel Installation

SECONDARY INSTALLATION

6. Ensure there is nothing on top of the media tray such as glass pebble media or glass bezel. Angle the rear liner into the firebox with finesse. The panel will fit in, don't worry, place one corner in towards the back and rotate inward. Slip it into the channel behind the media tray and install the rear liner retainer.

7. If you have media tray option 50-3332 (Glass Bezel) place the bezel strips around the tray before the side liners are installed. If you are using 50-3333 (Black Glass Media) or 50-3331 (Light Kit) install tray media after the side liners.

8. Place the side liners into the side channels of the media tray. 50-3328 (Ledgestone) and 50-3329 (Enameled) will be placed in at the bottom and rotated up until seated. 50-3326 (Fluted) will be placed in at the rear and rotated inward until seated. Once seated secure the top with the retainers using a T-20 Torx screwdriver. If using 50-3332 (Glass Bezel) pull the sides in so they butt up with the long strips.



Figure 74: Glass Bezel with Vermiculite Bed

9. If you are using 50-3333 (Black Glass Media) or 50-3331 (Light Kit) you may now cover the entire media tray in a thin layer of glass media; one layer is all you need.



Figure 75: Glass Media Bed

10. You have now successfully installed your panels and media base. You may now arrange your optional 50-3336 (Log Set); see instruction sheets for further detail.

IMPORTANT: IF THE AIR SLOT AROUND THE BURNER IS BLOCKED WITH MEDIA THIS WILL CAUSE THE FIREPLACE NOT TO BURN PROPERLY.

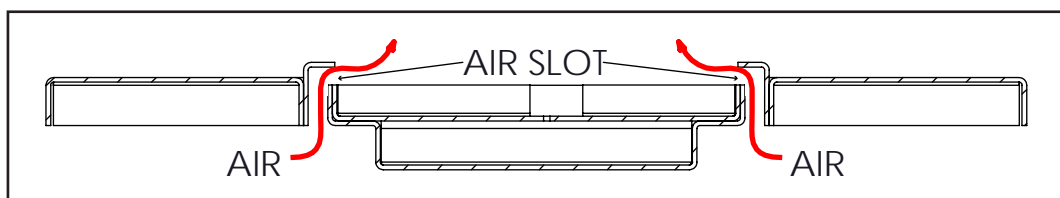

Figure 76: Burner Side Cross Section

SECONDARY INSTALLATION

LOG SET INSTALLATION:

The placement of the logs is not arbitrary. If they are positioned incorrectly, the flames can be “pinched” and will not burn correctly. Using the pictures provided, carefully set the logs in place. **NOTE: The logs are fragile and should be handled gently.**

1. Position Log #1 so it is touching the Left liner and is pushed up against the Back liner as shown. Position Log #2 so it is touching the Right liner and pushed up against the Back liner as shown.



2. Position Log #3, there are 3 points of contact to help position this log. Make sure there is contact with the left liner, the rear liner, and the front rebox edge. Position Log #4 on top of Log #2 and against the right liner and front rebox edge as shown.



3. Position Log #5 on the locating pin protruding from Log #3, there is a hole drilled into Log #5 which slides onto the pin. The other side of Log #5 will locate along the rebox front edge.



SECONDARY INSTALLATION

4. The C34 log set is now installed, the door can now be re-installed. The picture below shows a different angle.



FLAME APPEARANCE:

The pictures below show the proper flame appearance with and without logs. The flame should be fairly even with a few flame slightly taller than half the firebox height. If flames do not look correct there could be a venting issue, the media may need to be adjusted, or th wrong exhaust restrictor could be installed.



TROUBLE SHOOTING

Table 9: Troubleshooting

Problem	Possible Cause	Solution
Locking conditions	Reset the Proflame IFC board	· Turn the system off by pressing the ON/OFF button on the transmitter
		· After approximately 2 seconds press the ON/OFF button on the transmitter again.
		· In the manual flame control mode, use the down arrow button to reduce the flame to off, indicated by the word OFF displayed on the transmitter LCD screen.
		· Wait approximately 2 seconds and press the up arrow button, the ignition sequence will start.
Burners will not start	The pilot flame has gone out	· See "Pilot will not remain lit"
	The remote control is not working correctly	· Replace the batteries
	The thermostat is disconnected or set too high	· Set the thermostat to a lower temperature
	Problem with On/Off (X4) circuit	· Check the wiring connection at the X4 position on the IFC.
Flame lifting	Leak in vent pipe	· Check for leaks in vent connections
	Improper vent configuration	· Check vent configuration with manual
	Terminal may be re-circulating flue gases	· Check to see if terminal is on correctly
		· May need to install high wind termination cap. · Contact dealer
The heater has just been started	· Normal during start up: Minor flame lifting may occur on the elevated burners. Flames will settle as the fireplace heats up.	
Blue Flames	The heater has just been started	· Normal during start up: flame will yellow as the fireplace heats up. Let flames mature 15-20 minutes.
	Improper air shutter adjustment	· Adjust air shutter – contact your dealer
Glass fogs up	Normal condition: after the appliance warms up the glass will be clear.	**Due to additives in gas, glass may get hazy during operation** Clean as needed.
Flames are burning "dirty" or sooting	The logs are placed incorrectly	· Check log positioning
	Improper air shutter adjustment	· Increase primary air by opening the air shutter and/or by opening the vent restrictor
		· Check for proper venting and blockage of the vent termination
Incorrect rating input	· Check manifold pressure and clock input rating for over-firing	

If a particular flame is curving excessively your burner media not be evenly distributed creating an abnormal draft on the flame; position burner media in front of the secondary air slots in the affected area to slow down the draft. You can fine tune the flame this way to ensure healthy flame appearance.

TROUBLESHOOTING

Problem	Possible Cause	Solution
Locking conditions	Reset the Proflame IFC board	· Turn the system off by pressing the ON/OFF button on the transmitter
		· After approximately 2 seconds press the ON/OFF button on the transmitter again.
		· In the manual flame control mode, use the down arrow button to reduce the flame to off, indicated by the word OFF displayed on the transmitter LCD screen.
		· Wait approximately 2 seconds and press the up arrow button, the ignition sequence will start.
		· With the transmitter off, disconnect main power from stove for a few seconds then re-connect power.
		· Wait approximately 2 seconds and press the Reset button on the IFC
Main burners will not start	The pilot flame has gone out	· See "Pilot will not remain lit"
	The remote control is not working correctly	· Replace the batteries
	The thermostat is set too high	· Set the thermostat to a lower temperature
Flame lifting	Leak in vent pipe	· Check for leaks in vent connections
	Improper vent configuration	· Check vent configuration with manual
	Terminal may be re-circulating flue gases	· Check to see if terminal is on correctly
		· May need to install high wind termination cap.
Blue Flames	The heater has just been started	· Normal during start up: flame will yellow as the fireplace heats up
	Improper air shutter adjustment	· Adjust air shutter – contact your dealer
Glass fogs up	Normal condition: after the appliance warms up the glass will be clear.	**Due to additives in gas, glass may get hazy during operation** Clean as needed.
Flames are burning "dirty" or sooting	The logs or glasses are placed incorrectly	· Check log positioning
		· Check level of glasses layout
	Improper air shutter adjustment	· Increase primary air by opening the air shutter and/or by opening the vent restrictor
		· Check for proper venting and blockage of the vent termination
Incorrect rating input	· See also "Burners will not remain lit"	
		· Check manifold pressure and clock input rating for over-firing

PARTS DIAGRAM

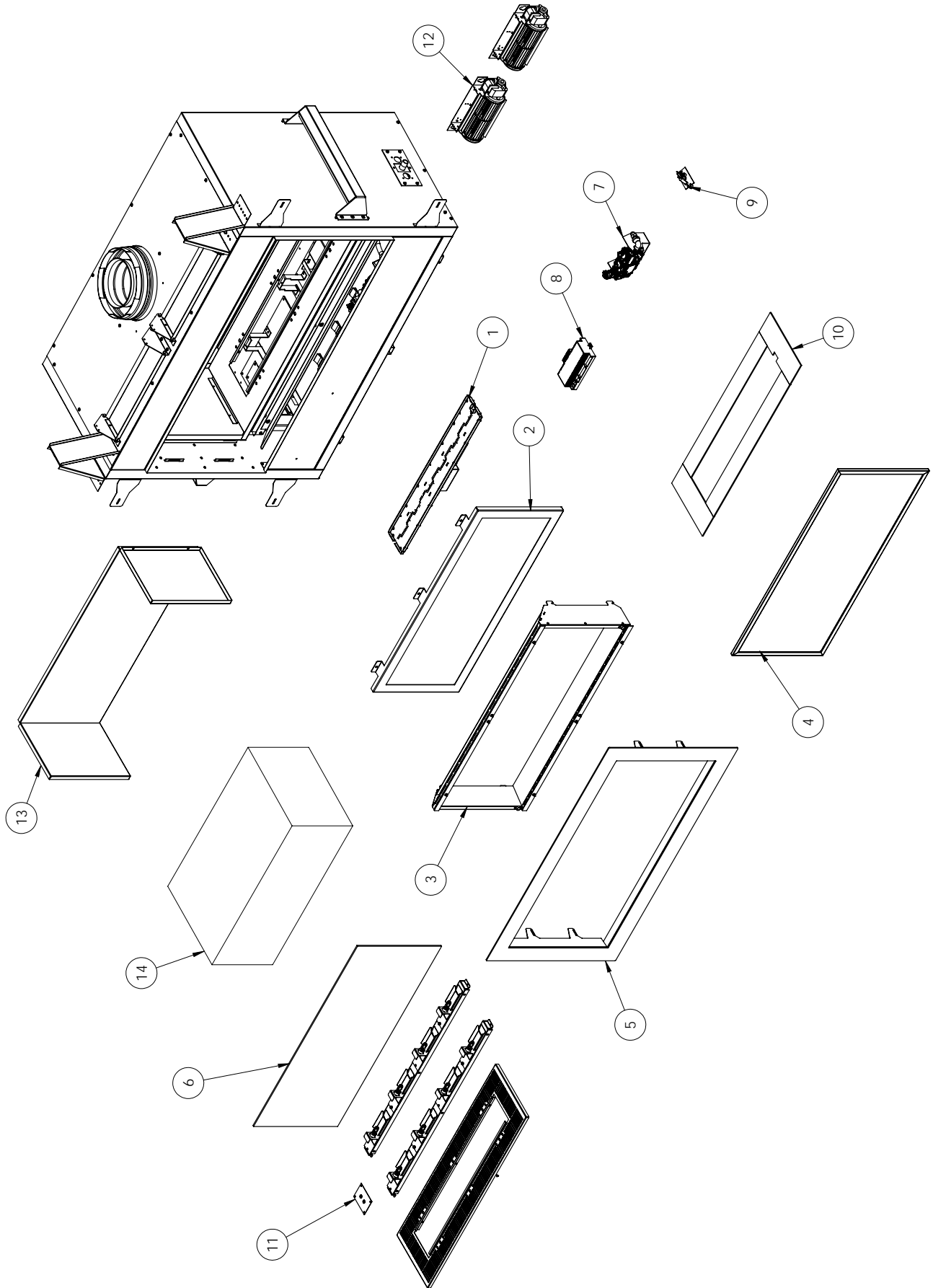

PARTS LIST

Table 9: C34I Parts List

Reference #	Part Description	Part #
1	C34 Pan Burner	50-3379
2	C34 Door Complete	50-3380
3	C34 Safety Screen Complete	50-4703
4	C34 Clear View Screen Only	50-3367
5	C34 Borderview Surround Powder Coated (Gray)	50-3325
5	C34 Borderview Surround Antique Copper	50-3364
6	C34 Door Glass with Gasket	50-3394
7	S.I.T. 885 Valve w/ NG Stepper Motor	50-1421
8	Proflame 2 IFC w/ 7 day Shutdown	50-4103
9	PSE Pilot Assembly - Intermittant Pilot (2021)	50-4058
10	C34 Glass Bezel Base w/ Vermiculite	50-3332
11	C34 Halogen Light Kit	50-3331
12	IPI Dual Convection Fan Kit (240 CFM Combined)	50-3760
13	C34 Fluted Liners	50-3326
13	C34 Ledgestone Liners	50-3328
13	C34 Porcelain Liners	50-3329
14	C34 Ultra High Definition Driftwood Log Set	50-3336
-	C34 Black Glass Media	50-3333
-	SIT NG to LP Conversion (Stepper Motor Only)	50-3753
-	IPI LP to NG Conv (StepperMotor Only)	50-3870
-	C34 Glass Bezel	50-3853
-	C34 Vermiculite (2 Cups)	50-3383
-	Replacement Fuse 3A	50-3289
-	35W Halogen Bulb	50-3291
-	C34I Owners Manual	50-3385
-	12 oz. Can of Matallic Black Touch Up Paint	PAINT-12-MB



Warranty for Enviro Gas Products

Sherwood Industries Ltd. ("Sherwood") hereby warrants, subject to the terms and conditions herein set forth, this product against defects in material and workmanship during the specified warranty period starting from the date of original purchase at retail. In the event of a defect of material or workmanship during the specified warranty period, Sherwood reserves the right to make repairs or to assess the replacement of a defective product at Sherwood's factory. The shipping costs are to be paid by the consumer. All warranties by Sherwood are set forth herein and no claim shall be made against Sherwood on any oral warranty or representation.

Conditions

- A completed warranty registration must be submitted to Sherwood within 90 days of original purchase via the online warranty registration page or via the mail-in warranty registration card provided. Have the installer fill in the installation data sheet in the back of the manual for warranty and future reference.
- This warranty applies only to the original owner in the original location from date of install.
- The unit must have been properly installed by a qualified technician or installer, and must meet all local and national building code requirements.
- The warranty does not cover removal and re-installation costs.
- Sherwood Industries Ltd. reserves the right to make changes without notice.
- Sherwood Industries Ltd. and its employees or representatives will not assume any damages, either directly or indirectly caused by improper usage, operation, installation, servicing or maintenance of this appliance.
- A proof of original purchase must be provided by you or the dealer including serial number.
- This warranty does not cover any discoloration of the safety screen mesh.

Exclusions

An expanded list of exclusions is available at www.enviro.com/help/warranty.html

This warranty does not cover:

- Damage as a result of improper usage or abuse.
- Damage caused from over-firing due to incorrect setup or tampering.
- Damage caused by incorrect installation.

To the Dealer

- Provide name, address and telephone number of purchaser and date of purchase.
- Provide date of purchase. Name of installer and dealer. Serial number of the appliance. Nature of complaint, defects or malfunction, description and part # of any parts replaced.
- Pictures or return of damaged or defective product may be required.

To the Distributor

- Sign and verify that work and information are correct.

Sherwood Industries Ltd.

6782 Oldfield Road, Victoria, BC . Canada V8M 2A3
 Online warranty registration: www.enviro.com/warranty/

Category	One Year	Two Year	Limited Lifetime (7yr)
Parts ^{1,2} (unit serial number required)		✓	
Firebox Liner Panels ³		✓	
Firebox			✓
Heat Exchanger			✓
Burner			✓
Ceramic Logs ⁴			✓
Ceramic Glass ⁵	✓		
Pedestal / Legs (excluding finish)			✓
Door Assembly			✓
Surround Panels (excluding finish)			✓
Exterior Panels (excluding finish)			Up to 5 years
Electrical Components		✓	
Exterior Surface Finishing	✓		
Labour	✓		

¹ Whereas warranty has expired, replacement parts will be warrantied for 90 days from part purchase date. Labour not included. Unit serial number required.

² 50-173 Westport Fan Kit covered for up to 5 years from purchase date. Labour not included. Unit serial required.

³ Excluding damage to the finish caused by improper setup of the appliance, or color changes.

⁴ Log set and panels excludes wear and tear or breakage caused by cleaning or service.

⁴ Glass is covered for thermal breakage. Photos of box, inside of door, and unit serial # must be supplied for breakage due to shipping.

⁶ Exterior Surface finishing covers plating, enamel or paint and excludes colour changes, chipping, and fingerprints. Travel costs not included.

INSTALLATION DATA SHEET

The following information must be recorded by the installer for warranty purposes and future reference.

NAME OF OWNER:

ADDRESS:

PHONE: _____

NAME OF DEALER:

ADDRESS:

PHONE: _____

MODEL: _____

SERIAL NUMBER: _____

DATE OF PURCHASE: _____ (dd/mm/yyyy)

DATE OF INSTALLATION: _____ (dd/mm/yyyy)

NATURAL GAS (NAT) PROPANE (LPG)

INLET GAS PRESSURE: _____ in wc

MAIN BURNER ORIFICE: _____ # DMS

PILOT ORIFICE # _____ OR _____ in diam.

INSTALLER'S SIGNATURE:

NAME OF INSTALLER:

ADDRESS:

PHONE: _____

MANUFACTURED BY:
SHERWOOD INDUSTRIES LTD.
6782 OLDFIELD RD. SAANICHTON, BC, CANADA V8M 2A3
www.enviro.com
February 2026
C-17471